

RO/HOBBY

1:10 MASHIGAN

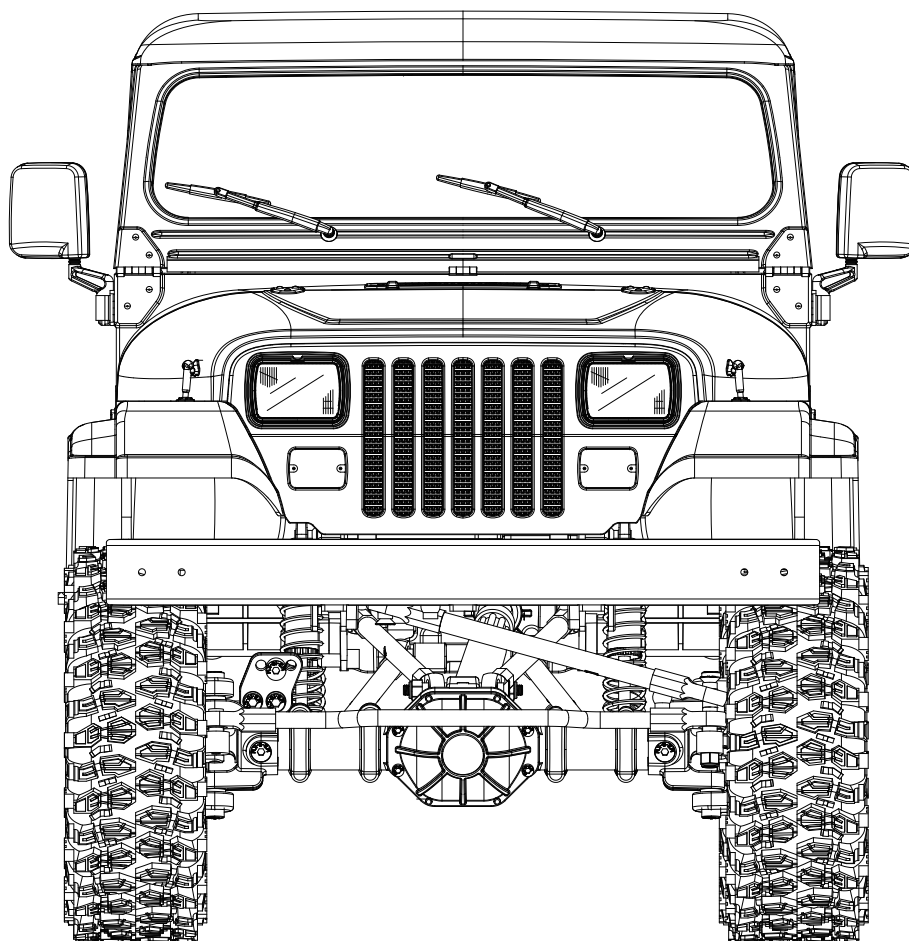

Instruction Manual
Bedienungsanleitung
Manuel d'utilisation
操作手册

SPECIFICATION

Length: 546mm
Width: 274mm

Height: 282mm
Wheel base: 330mm

Ground clearance: 82mm
Approach angle: 68°

Departure angle: 47°

Introduction

Humanity's desire for individuality and conquest is engraved into the bones and blood of this car. As the most recognizable SUV in the world, it can climb the extremity of the Rubicon or speed in the Sahara desert. She came from the war, and every detail is full of classics. The starting point of this saga was the 1986 Chicago Auto Show. The first-generation model had sharp edges and corners, and it had not yet bowed to the city and the air at that time, and luxury and comfort had nothing to do with it.

Later models talked about the Open air full convertible design, which seemed quite a gimmick, while the first-generation model adopted a similar design as early as 36 years ago. And I'm never going to tell you that this 1:10 MASHIGAN model can remove the entire roof to reveal a full interior. The windshield can be tipped forward and transformed into a fully open top. The super soft rubber seat allows the figure to have a more comfortable sitting posture. A sturdy built-in nylon roll cage protects the interior and figure in the event of a rollover. Behind the single-row seats is a delicate car hopper, and of course the tailgate can be opened, which is convenient for loading various groceries, showing another personality of the owner. The doors on both sides can not only be opened, but also disassembled like a real car. You are the real cowboy when you remove the doors. The hood can be opened, and the 35T550 motor, high-quality brush ESC and the receiver are hidden underneath, which is quite convenient for operation.

For adventurers, the road ahead is always rough and full of thorns, but whether there is a road or no road, the 1.9 inch climbing tires can give you confidence, and meanwhile, the four-link suspension system gives you a guarantee of strong power, the metal trapezoidal beams provide you with a solid supportive structure. Even with a hard plastic car shell with a complete interior, it can easily overcome extreme road conditions. The real first-generation model uses leaf spring suspension, and adventurers will not ignore the history, the chassis can be installed with leaf spring suspension (sold separately) to restore the style of the first generation model. Pursuing the needs of climbing performance and restoration seems to be impossible, but through the compatible design of the chassis and the replacement of a few accessories, it can show a completely different shape. Two postures, and double the fun.

The exquisite interior and four-door full-opening design double the level of detail of this hard-shell RC model, which can be viewed statically or operated indoors. The climbing-level sturdy chassis and suspension system make it cool to go wild!

Features

- Ready set
- Ball bearings full set
- Polystyrene body
- Nice painted body
- Hood can be opened
- Both side doors can be opened
- 1.9-inch AT tire
- Tailgate can be opened
- Super exquisite interior
- Soft rubber seat
- Nylon roll cage
- Steel c-channel frame
- Four link suspension
- 35t 550 motor

Transmitter instruction

The FS-G4P is a simple 4 channel transmitter using the latest AFHDS 2.4GHz ATN frequency hopping technology. Designed to be sleek, passionate and powerful for entry level enthusiasts.

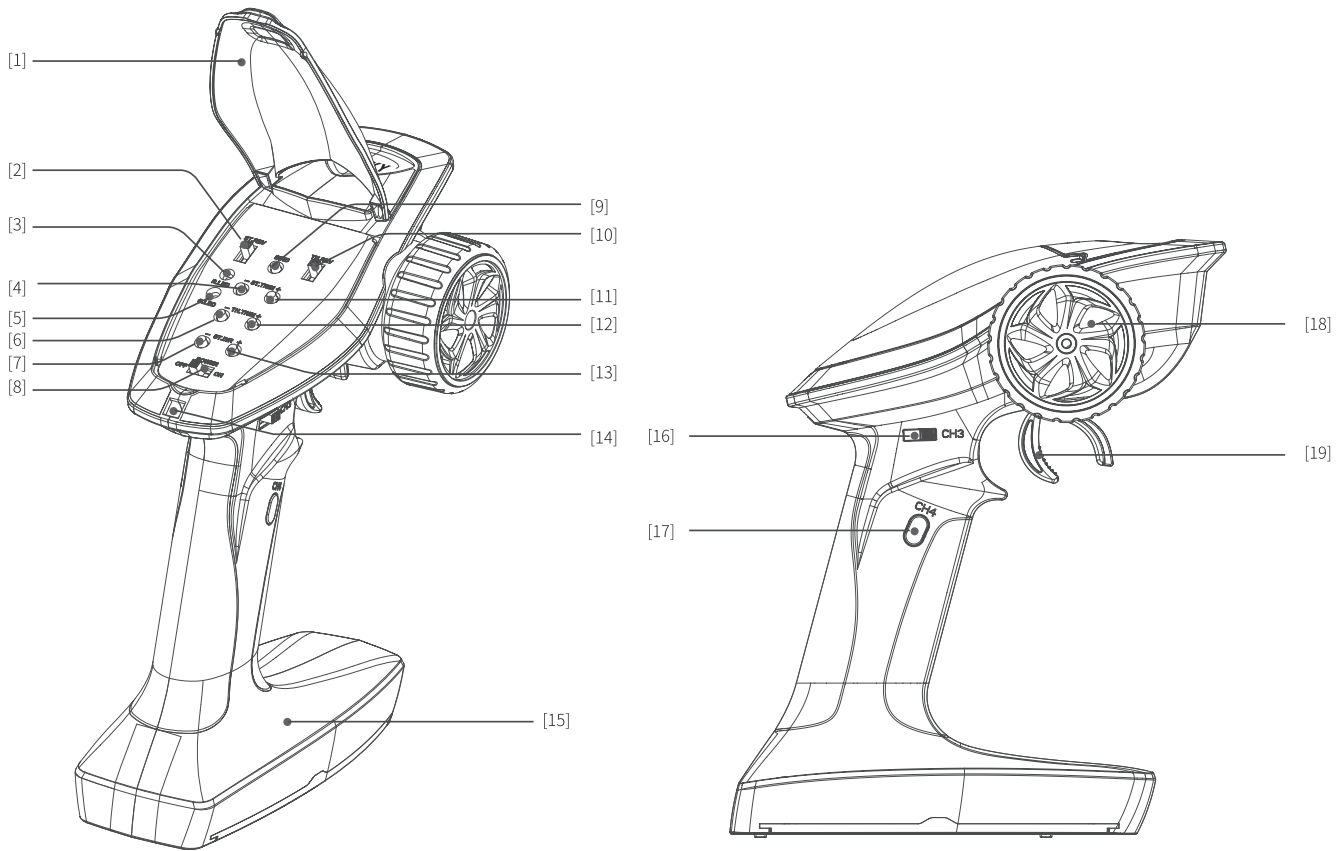







[1]	Panel Flip Cover	[11]	Steering Trim (ST.TRIM +)
[2]	Steering Reverse Switch (ST.REV)	[12]	Throttle Trim (TH.TRIM +)
[3]	Power indicator LED (R. LED)	[13]	Steering D/R (ST.D / R +)
[4]	Steering Trim (ST.TRIM-)	[14]	Lanyard Eye
[5]	Status indicator green LED (G.LED)	[15]	Base, 4 * AA battery compartment
[6]	Throttle Trim (TH.TRIM-)	[16]	Three-position switch (CH3))
[7]	Steering D/R (ST.D / R-)	[17]	Button (CH4)
[8]	Power Switch	[18]	Wheel Angle, the maximum rotation of the steering wheel is 35 degrees from center to left or right (CH1)
[9]	Bind Button (BIND)	[19]	Throttle trigger, has a total throw of 12 degrees, 12.5 degrees for backward (CH2)
[10]	Throttle Reverse (TH.REV)		

Getting Started

Before operation, install the battery and connect the system as instructed below.

★ Transmitter Battery Installation

 Danger	Only use specified battery (X4 AA batteries).
 Danger	Do not open, disassemble, or attempt to repair the battery.
 Danger	Do not crush/puncture the battery, or short the external contacts.
 Danger	Do not expose to excessive heat or liquids.
 Danger	Do not drop the battery or expose to strong shocks or vibrations.
 Danger	Always store the battery in a cool, dry place.
 Danger	Do not use the battery if damaged.

Battery Type: AA

Battery Installation:

1. Open the battery compartment cover.
2. Insert 4 fully-charged AA batteries into the compartment. Make sure that the battery makes good contact with the battery compartment's contacts.
3. Replace battery compartment cover.

Low battery alarm: When the battery is lower than 4.2v, the G.LED on the panel will flash slowly.

Instructions



After setting up, follow the instructions below to operate the system.

1、 Power On

Follow the steps below to turn on the transmitter:

1. Check to make sure that that battery is fully charged and installed correctly.
2. Toggle the switch to the [ON] position. When active the R.LED will be lit.
3. Connect the receiver to power.

For safety always power on the transmitter before the receiver.

 Note	Operate with caution in order to avoid damage or injury.
 Note	Make sure that the throttle is at its lowest position and the switches are set to their up position.

2、Binding(The transmitter and receiver have already been bound at the factory)

If the transmitter or receiver need to be replaced, bind follow these steps:

- 1.Turn on the transmitter while holding the bind button to enter bind mode. G.LED will start flashing quickly: Once in bind mode release the bind button.
- 2.The receiver will enter bind mode atomically when powered on.
- 3.Once binding is successful the receiver' s LED will flash slowly and the transmitter' s LED will remain solid after being rebooted.

Note: When binding, put the transmitter into bind mode first, then the receiver.

- Applicable to the FS–G4P transmitter and the FR–R4P receiver. Different receivers have different bind procedures. For more information visit the ROC Hobby website for manuals and other related information.
- Product information is updated regularly, please visit our website for more information.

3、Stick Calibration(This function is used to set the neutral position for throttle and wheel)

Every transmitter is calibrated before leaving the factory, however if recalibration is required,please follow these steps:

- 1.Turn and hold the wheel as far clockwise as it will turn, hold the throttle all the way forward,then turn on the transmitter in calibration mode.
 - The R.LED and G.LED will flash twice.
- 2.Calibrate wheel: Turn the wheel completely clockwise, then completely counterclockwise.
 - When calibration is completed the R.LED will be off.
- 3.Trigger calibration: Pull the trigger back then forward as far as it will go.
 - When calibration is completed the G.LED will be off.
- 4.Once calibration is complete press the bind key to save and exit.

4、Power Off

Follow the steps below to turn off the system:

- 1.Disconnect the receiver power.
- 2.Toggle the transmitter's power switch to the off position.



Danger

Make sure to disconnect the receiver power before turning off the transmitter. Failure to do so may lead to damage or serious injury.

System Functions

This section focuses on the functions and how to use them.

1、Channel Description

The transmitter outputs a total of 4 channels, which are allocated as follows:

1. CH1: Steering Wheel
2. CH2: Throttle Trigger
3. CH3: Three–position Switch
4. CH4: Reset Button

Note: By default the output of CH4 is 1000us, pressing the button will toggle between 1000 and 2000us.

2、Channel Reverse

This function is used to adjust each channels direction of movement in relation to it's input.

The ST.REV / TH.REV switches are the reverse buttons for CH1 and CH2. If the switch is up it indicates reverse, and the down indicates normal.

3、Trims

The ST.TRIM is the trims for CH1 (steering),and can be multiplexed as trims of CH3 and CH4.

For multiplexing switching mode, refer to [5 Mode Switching].

TH.TRIM is the trims for CH2(throttle).

Adjustment range: $-120\mu s$ – $+120\mu s$, each step is $4\mu s$;

ST.TRIM + / TH.TRIM +: Increases adjustment step;

ST.TRIM– / TH.TRIM–: Decreases adjustment step.

LED Indicator:

When using the trim keys the G.LED will flash slowly on short presses and quickly on long presses.

When the trim adjustment value is at the netrual position, the G.LED will flash twice slowly.

When the trim adjustment value is at both ends ($+120\mu s$ / $-120\mu s$), the trim adjustment is at its maximum and as such G.LED will not flash(If the fine adjustment value has been adjusted to $+120\mu s$, then press ST.TRIM + / TH.TRIM + key is invalid and G.LED has no indications.)

4、D/R

ST.D / R is for servo travel adjustment, which can be multiplexed as CH2 (throttle), CH3, CH4 servo travel adjustment, refer to [5 Mode Switch] for multiplex switching mode;

Adjustment range: 0 – 120% (the default is 100%), the step is 5% .

ST.D / R +: Increases servo travel.

ST.D / R –: Decreases servo travel.

LED Indicator:

When using the trim keys the G.LED will flash slowly on short presses and quickly on long presses.

When the ratio value is at both ends ($0/120\%$), the ST.D / R button is at its maximum and as such G.LED will not flash(if the ratio value has been adjusted to 120% , then press ST.D/R+ key is invalid and G.LED has Instructions)

5、Mode switching

This function is for reusing the ST.TRIM and ST.D / R buttons for different channels (Refer to [3 Trims] and [4 D/R]).

Function setting:

Under normal power–on, quickly press the Bind button twice (within 1 second) to cycle through modes 1, 2, 3, and 4. The default setting when powering on is mode 1.

Mode 1: G.LED flashes slowly once, ST.TRIM is CH1 trim adjustment, ST.D / R is servo travel adjustment.

Mode 2: G.LED flashes twice slowly, ST.TRIM is CH1 trim adjustment, ST.D / R is CH2 servo travel adjustment.

Mode 3: G.LED flashes three times slowly, ST.TRIM is CH3 trim adjustment, ST.D / R is CH3 servo travel adjustment.

Mode 4: G.LED flashes slowly four times, ST.TRIM is CH4 trim adjustment, ST.D / R is CH4 servo travel adjustment.

6、Failsafe

This function dictates what the receiver will do in the event that it loses signal from the transmitter, this includes servo position etc.

Function settings:

1. Turn on the transmitter and make sure it is connected to the receiver.
2. Hold the control surface at the desired failsafe position.
3. Press and hold the bind button for 3 seconds, if the G.LED starts flashes for 2 seconds, indicating that the settings are successful.

Note: The fail-safe function has no default set at the factory and as such must be set manually. If no failsafe setting has been set, then the receiver will not output anything when signal is lost.

7、Beginner Mode

Beginner mode is designed for the people who is new to the hobby.

In this mode the throttle has been limited to 50 percent, The channel range defaults has been set to 1250~1500~1750us.

Function settings:

To switch between beginner and normal modes, press and hold the CH4 button while turning the steering wheel completely counterclockwise as far as it can, and at the same time, power on the transmitter.

Note: By default, the system is set to normal mode. If the system has set to beginner mode.

BThe G.LED will be in a state of two-time flashing and on off, and keep the state for 3 seconds during power on.

Instructions

1、Transmitter specification (FS-G4P)

Product Model	FS-G4P
Channels	4
Model Type	Car, Boat
RF	2.4GHz
RF Power	<20dBm
2.4GHz Protocol	ANT
Distance	>300m (Ground)
Channel Resolution	1024
Battery	6V DC 1.5AA*4
Charging Interface	NO
Life time	According to battery type
Low Voltage Warning	<4.2V
Antenna Type	Built-in single antenna
Data Interface	No
Temperature Range	-10°C ~ +60°C
Humidity Range	20-95%
Online Update	No
Color	Black
Size	160*193*97mm
Weight	220g
Certification	CE, FCC ID:N4ZG4P00

Receiver overview

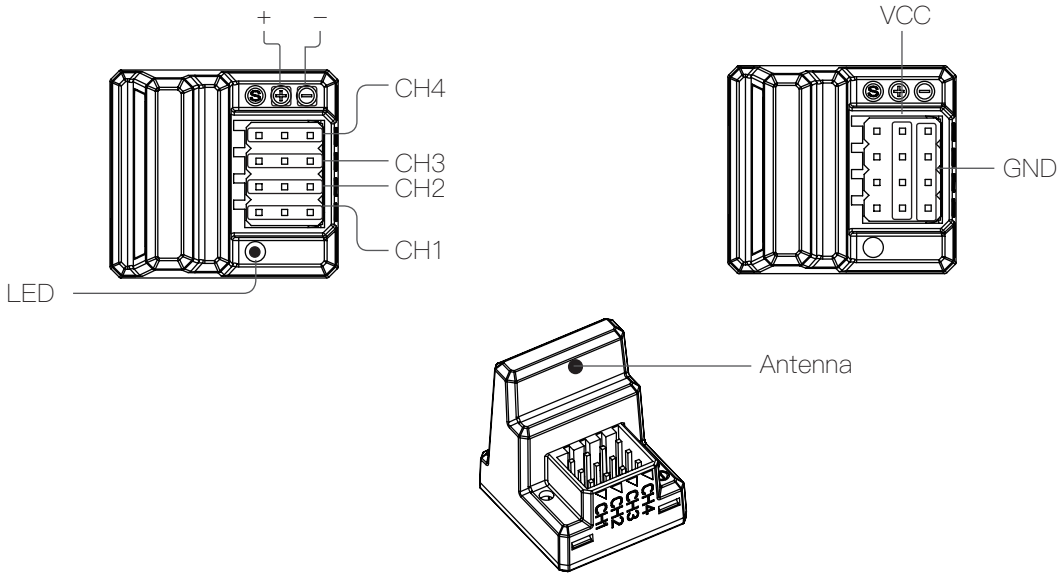

Note To ensure the best signal quality make sure that the antenna is mounted perpendicular to the model body in an upright position.

1、Receiver specifications FS-R4P

Product Model	FS-R4P
PWM channel	4
RF	2.4GHz
2.4GHz Protocol	ANT
Distance	>300m (Ground)
Antenna Type	Built-in single antenna
Power supply	3.5-8.4V
RSSI	NO
Data Interface	PWM
Temperature Range	-10°C—+60°C
Humidity Range	20—95%
Online Update	NO
Size	22.6*20.6*25.5mm
Weight	6g
Certification	CE, FCC

Throttle stick position

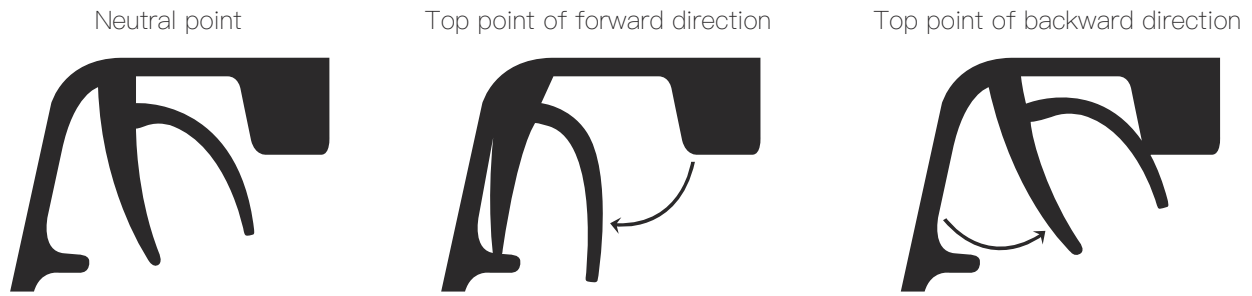

Model		WP-1040-BRUSHED WP-1040-BRUSHED-Crawler& Boat *
Cont. / Burst Current		Forward: 40A / 180A Backward: 20A / 90A
Input		2-3S Lipo, 5-9 Cells NiMH
Cars Applicable		1:10 on-road, off-road Buggy, Truggy, SCT 1:10 Crawler, Tank & Boat
Motor Limit	2S Lipo or 5-6 cells NiMH	540 or 550 size motor ≥12T or RPM < 30000 @7.2V
	3S Lipo or 7-9 cells NiMH	540 or 550 size motor ≥18T or RPM < 20000 @7.2V
Resistance		Fwd: 0.002 Ohm, Bwd: 0.004 Ohm
Built-in BEC		2A/6V (Linear mode BEC)
Dimension & Weight		WP-1040-BRUSHED: 46.5*34*28.5, 65g WP-1040-BRUSHED-CRAWLER: 46.5*34*28.5, 70g

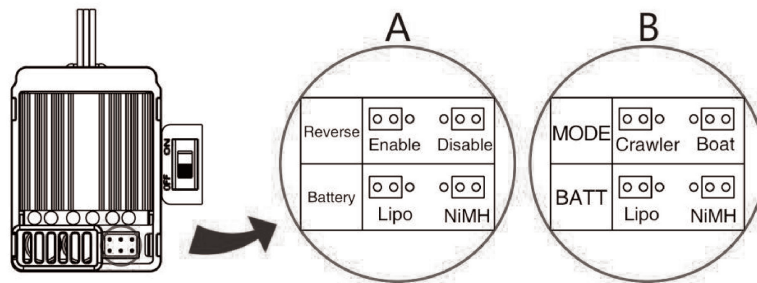

A:WP-1040-BRUSHED
B:WP-1040-BRUSHED-CRAWLER & BOAT

Trouble	Possible Reason	Solution
After power on, motor can't work, no sound is emitted, and LED is off.	The ESC doesn't get its working voltage; Connections between battery pack and ESC are broken.	Check the battery wires connection or replace the defective connectors.
	Switch is damaged.	Replace the switch.
After power on, motor can't work; red LED blinks.	Throttle signal is abnormal.	Check the throttle wire connection; make sure it is plugged into the throttle channel of the receiver.
	Automatic throttle range calibration is failed.	Set the "TRIM" of throttle channel to 0 or turn the knob to its neutral position.
The car runs backward while giving throttle. (The motor runs in the opposite direction.)	The wire connections between ESC and the motor need to be changed.	Swap two wire connections between the ESC and the motor.
The car can't go backward.	The jumper position is wrong.	Check the jumper and plug it to the correct position.
	The neutral point of throttle channel is changed or drifted.	Set the "TRIM" of throttle channel to 0 or turn the knob to its neutral position.
The car can't go forward, but can go backward.	The direction of throttle channel is not correct.	Reset the direction of throttle channel from original "NOR" to "REV", or from original "REV" to "NOR".
The motor doesn't work, but the LED in the ESC works normally.	The connections between motor and ESC are broken.	Check the connections and replace the defective connectors.
	Motor is damaged.	Replace the motor.
The motor suddenly stops running while in working state.	The throttle signal is lost.	Check the transmitter and the receiver. Check the throttle wire connection.
	Low voltage cut-off protection or Over-heat cut-off protection has been activated.	Replace the battery pack, or cool down the ESC.
The car cannot get top speed and the red LED doesn't solid on at full throttle.	Some setting in the transmitter are incorrect.	Check the settings. Set D/R, EPA, ATL to 100% or turn the knobs to maximum value. Set TRIM to 0 or turn the knob to its neutral position.
Motor is cogging when accelerated quickly.	The battery has limited discharge ability.	Use battery with better discharge ability.
	Motor RPM is too high, the gear ratio is too aggressive.	Use motor with lower RPM, or use smaller pinion to get softer gear ratio.
	Something wrong in the driving system of the car.	Check the driving system of the car.

Operating the vehicle

Step 1: turn on the transmitter, the headlamp of the transmitter will flash and enter the frequency matching mode.

Step 2: turn on the receiver switch, the headlight will flash and enter the frequency matching mode.

Step 3: when the transmitter and receiver are successful in frequency up, the front lights of the transmitter will be on for a long time, and the front lights of the vehicle will be off.

Charging the Battery

- Always charge LiPo batteries on non-flammable, heat-resistant surfaces.
- Always use a LiPo-safe bag or container while charging. Do not allow LiPo cells to overheat at any time. Cells which reach greater than 140 Fahrenheit(60°C) will usually become damaged and will catch fire.
- Do not charge the LiPo pack while it is still in the model. Never charge or store battery packs in a vehicle.
- Do not discharge LiPo; doing so will damage the battery.
- Do not expose LiPo cell to water or moisture at any time.
- Do not store battery near open flame or heater.
- Do not assemble LiPo cells or pre-assembled packs together with other LiPo cells or packs.
- Always store LiPo battery in a secure location away from children.
- Always remove the LiPo battery if model is involved in any kind of crash.
- Carefully inspect the battery and connectors for even the smallest damage.
- CAUTION: Cells may become hot after usage. Allow the pack to cool to room temperature prior to recharging.
- Do not allow the electrolyte to get into eyes or on skin. Wash affected areas immediately if they if they come into contact with electrolyte. Do not alter or modify connectors or wires of a LiPo battery pack.
- Always inspect the condition of the battery before charging and operating.
- Do not short circuit the LiPo battery.
- Do not have contact with a leaky/damaged battery directly.
- Do not charge battery out of recommended temperature range(0°C–45°C).

**NOTE**

1. If it is not in use for a long time, unplug and take off the battery to prevent battery leakage.
2. The battery needs to be disconnected and take off from vehicle before it can be charged
3. Do not open, disassemble, or attempt to repair the battery.

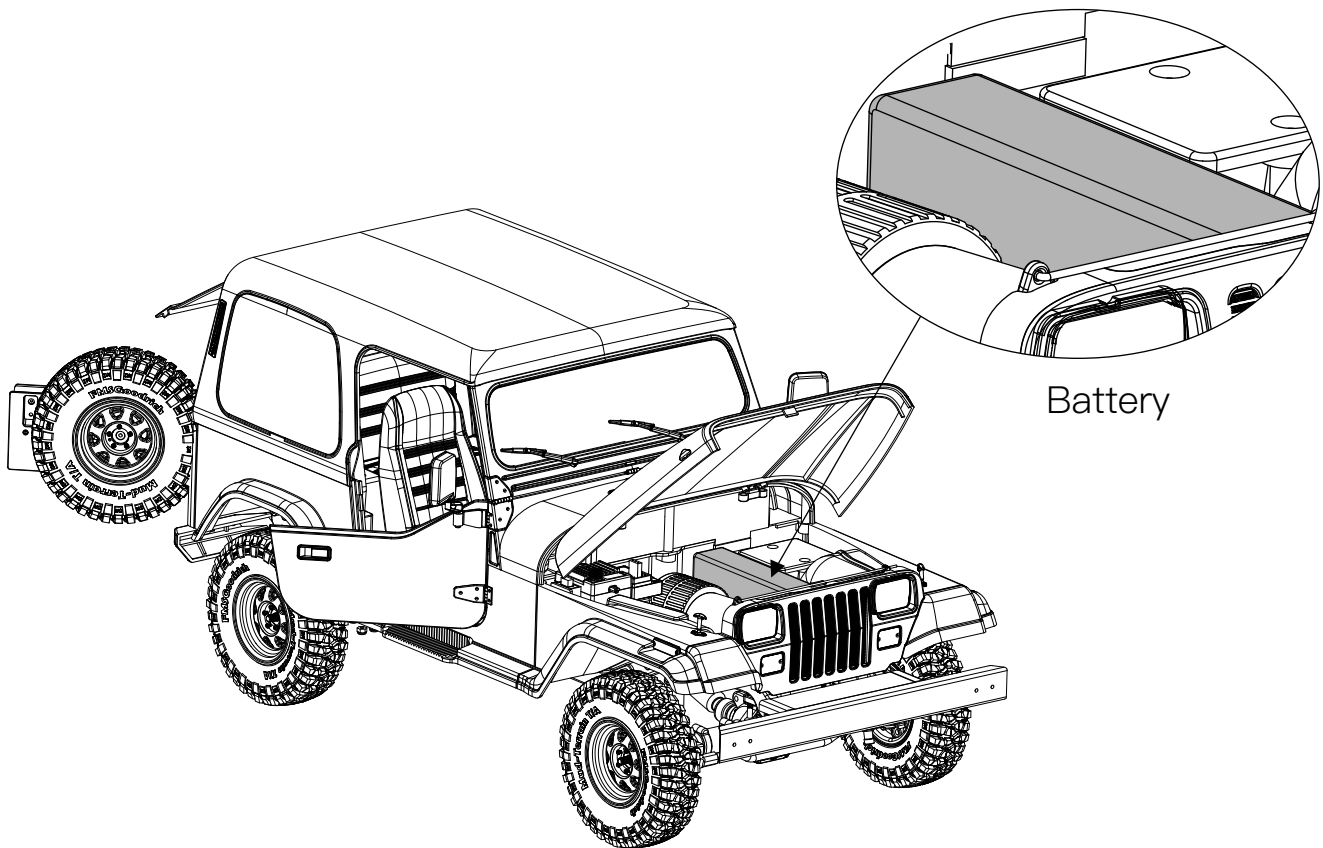
**CE Warning**

The antenna(s) used for this transmitter must be installed to provide a separation distance of at least 20 cm from all persons and must not be co-located or operating in conjunction with any other transmitter. End-users and installers must be provided with antenna installation instructions and transmitter operating conditions for satisfying RF exposure compliance.

Appendix 1 FCC Statement

This equipment has been tested and found to comply with the limits for a Class B digital device pursuant to part 15 of the FCC rules. These limits are designed to provide reasonable protection against harmful interference in a residential installation. This equipment generates, uses and can radiate radio frequency energy and, if not installed and used in accordance with the instructions, may cause harmful interference to radio communications. However, there is no guarantee that interference will not occur in a particular installation. If this equipment does cause harmful interference to radio or television reception, which can be determined by turning the equipment off and on, the user is encouraged to try to correct the interference by one or more of the following measures:

- Reorient or relocate the receiving antenna.
- Increase the separation between the equipment and receiver.
- Connect the equipment into an outlet on a circuit different from that to which the receiver is connected.
- Consult the dealer or an experienced radio/TV technician for help.

To assure continued compliance, any changes or modifications not expressly approved by the party responsible for compliance could void the user's authority to operate this equipment.

This equipment complies with Part 15 of the FCC Rules. Operation is subject to the following two conditions:

- (1) This device may not cause harmful interference.
- (2) This device must accept any interference received, including interference that may cause undesired operation.

Caution!

The manufacturer is not responsible for any radio or TV interference caused by unauthorized modifications to this equipment. Such modifications could void the user authority to operate the equipment.

1. The antenna(s) used for this transmitter must be installed to provide a separation distance of at least 20 cm from all persons and must not be co-located or operating in conjunction with any other transmitter. End-users and installers must be provided with antenna installation instructions and transmitter operating conditions for satisfying RF exposure compliance.

2. Move all your channels to the desired position.

3. Select [All channels] and then [Yes] in the confirmation box.

Declaration of Conformity (DoC)

We,
Add: Room 701, Block B, Luo Tian Community
Xiangshan Road 142, Songgang Street, Shenzhen
Baoan District China

Phone: 0769-86976655
Web: www.rochobby.com

declare under our responsibility that the product:

Type of Equipment: Driving System & 2.4GHz Control System

Brand Name: Rochobby

Compatible for cars: 1 : 10 MASHIGAN

Equipment Model: 11033



to which this declaration relates is in conformity with the essential requirements and other relevant requirements of the Directive 2014/53/EU, EMC Directive 2014/30/EU, EMC Directive 2014/53/EU, FCC Identifier N4ZG4P00, EU RoHS Directive 2011/65/EU and Council Directive 2014/30/EU. The product is in conformity with following standards and/or other normative documents:

- ETSI EN 301 489-1 V2.2.3(2019-11)
- ETSI EN 301 489-17 V3.2.4(2020-09)
- EN 55032:2015+A11:2020
- EN 55035:2017+A11:2020
- EN61000-3-2:2014
- EN61000-3-3:2013
- EN : 62479:2010
- ETSI EN 300 328 V2.2.2 (2019-07)

C1011	Main Gear Box Set	C1418	Screw Nut Set
C1010	Transmission Shaft Assembly	C1419	Pin Lock Set
C1391	Transmission Gear Box Assembly	C1420	Bearing Set
C1021	12mm Wheel Hex Set	C1421	Slipper Spring
C1392	Climbing Tyres	C1422	Slipper Pad
C1393	Climbing Wheels	C1423	Spur Gear 42t 0.6
C1394	11033 Front Axle Assembly	C1424	5.8 Ball Head
C1395	11033 Front Axle Plastic Parts	C1425	Gear Set
C1396	11033 Front Oil Shock Absorbers Assembly(2pcs)	C1080	35t Brushed 550 Motor
C1397	11033 Rear Oil Shock Absorbers Assembly(2pcs)	C1081	Gasket Set
C1398	Steering C Hub Parts	C1426	Front Outdrive Shaft Assembly
C1399	Steering Link	C1427	R Drive Cup Set
C1400	11033 Rear Axle Assembly	C1428	Aluminium Steering C Hub Parts
C1401	Rear Wheel Shaft	C1084	Bushing Set
C1402	11033 Rear Axle Plastic Parts	C1429	Aluminium Steering Bracket Set
C1403	11033 Window Frame	C1430	Pinion Gear
C1404	11033 Wiper Set	C1101	Metal Transmission Shaft
C1405	11033 Seat Set	C1105	2.4g Transmitter Fibre Stbre
C1406	11033 Front Bumper Set	C1106	2.4g Transmitter Fibre Stbre & Receiver Set
C1407	11033 Rear Bumper Set	C1035	9g Servo For Steering Wheel
C1408	11033 Mirror Set	C1431	11033 Led Light Wire Set
C1409	11033 Lens Set	C1108	Waterproof 40a Brushed Esc
C1410	11033 Rear Door	C1335	2.4g Receiver Set
C1411	11033 Rear Door Link	C1432	11033 Car Body
C1412	11033 Shift Bar Arm Set	C1433	11033 Light Cup
C1413	11033 Steering Wheel Set	C1434	11033 Door Set
C1414	11033 Hood	C1435	11033 Windows Set
C1415	11033 Hood Lock	C1436	11033 Roof Cover
C1416	11033 Roll Cage	C1437	11033 Instrument Panel
C1417	11033 Spare Tire Rack	C1438	11033 Screw Set
C1009	Ball Cap For Linkage & Rod		

产品介绍

人类对个性和征服的渴望作为基因刻入这台车的骨血。世界上最具辨识度的SUV，可以在卢比肯Rubicon绝经攀爬，可以在撒哈拉Sahara沙漠飞驰。她从战火中走来，每处细节都写满经典。这段传奇的起点是1986年的芝加哥车展。初代车型棱角分明一身傲骨，那时还没有向城市和空气低头，豪华舒适更与我无关。

如今后辈车型把Open air全敞篷设计挂在嘴边，似乎颇具噱头，而初代车型早在36年前就采用了同类设计，而我也绝不会告诉你这台1:10 探险家可以拆掉整个车篷呈现出完整内饰。风挡可以向前翻倒，变身完全敞篷的形态。超软胶座椅可以让人偶有更加贴合的坐姿。坚固的内置尼龙防滚架则可以在翻车意外时保护内饰和人偶。单排座椅的后面是精巧的后斗，尾门当然可以打开，方便装载各式杂货，演出车主的另一个人设定。两侧车门不仅可以打开，还可以像实车一样拆卸，摘除车门你才是牧马的人。引擎盖可以打开，下面隐藏的是35T550电机、高品质有刷电调和接收机，设定操作十分方便。

对探险家来说，前进的道路上总是崎岖与荆棘，有路或是没有路，1.9寸攀爬轮胎都不在乎，四连杆悬挂系统是强悍的保证，金属梯形大梁提供坚实的支撑。即使搭载拥有完整内饰的硬塑料车壳，也能轻松克服极端路况。真正的初代车型采用钢板弹簧悬挂，而探险家不会忽视历史，底盘可以安装钢板弹簧悬挂（另购）还原初代车型的韵味。追求攀爬性能和仿真还原的需求，似不可兼得，但通过底盘的兼容设计，更换少量配件，既可呈现出完全不同的形态，两种姿态，双倍乐趣。

精美的内饰和四门全开设计让硬壳遥控车细节密度翻倍，静静观看也好，室内小跑也妙。标准攀爬车坚固底盘和悬挂系统，徒步穿越也行，户外玩耍也爽，天生探险家当然出去野！

产品特点

- 组装完成品
- 全车滚珠轴承
- 仿真硬塑料车壳
- 引擎盖可开启
- 两侧车门可开启
- 尾门可以开启
- 1.9寸全地形轮胎
- 超精美内饰
- 软胶座椅
- 尼龙防滚架
- 金属C形大梁
- 经典四连杆悬挂
- 可更换为钢板弹簧悬挂（另购）
- 35T 550大扭力电机

发射机概览

FS-G4P是一款使用富斯最新自主研发的2.4GHz ANT蚂蚁版自动跳频数字系统的简版4通道发射机，外观采用跑车元素彰显速度、激情和力量，该款发射机还具备初学者模式方便入门玩家使用。

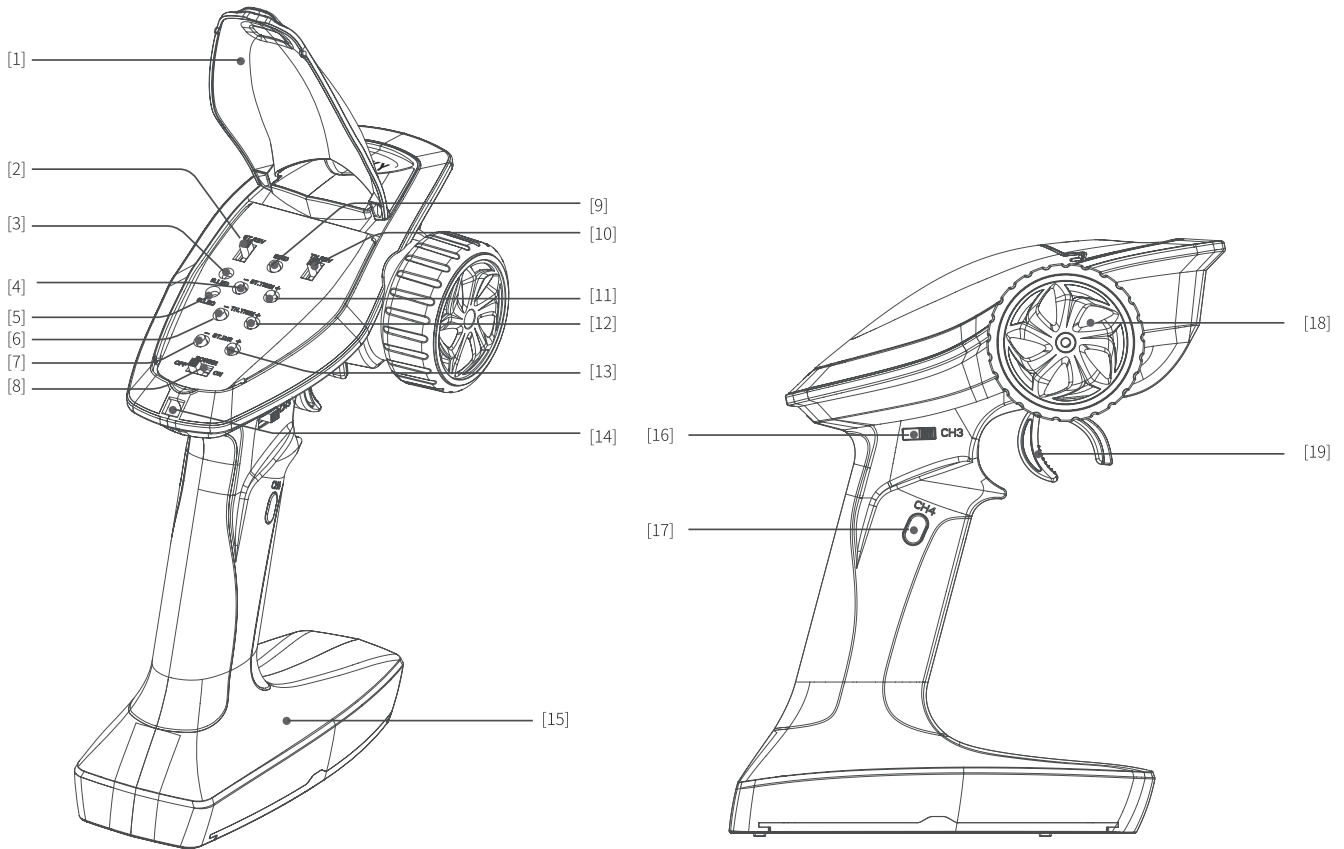







[1]	功能面板保护盖	[11]	方向微调按键 (ST.TRIM+)
[2]	方向倒置开关 (ST.REV)	[12]	油门微调按键 (TH.TRIM+)
[3]	电源指示灯红色LED (R.LED)	[13]	方向比例调节按键 (ST.D/R+)
[4]	方向微调按键 (ST.TRIM-)	[14]	挂绳孔
[5]	状态指示灯绿色LED (G.LED)	[15]	底座, 4*AA电池仓
[6]	油门微调按键 (TH.TRIM-)	[16]	三档拨动开关 (CH3)
[7]	方向比例调节按键 (ST.D/R-)	[17]	按键开关 (CH4)
[8]	电源开关	[18]	方向手轮, 左右各35度 (CH1)
[9]	对码按键 (BIND)	[19]	油门扣机, 前25度后12.5度 (CH2)
[10]	油门倒置开关 (TH.REV)		

使用前准备

开始操作前，请按照本章的顺序和指引安装电池、连接设备。

★发射机电池安装

 危险	仅使用厂家指定的电池。
 危险	请勿打开、拆卸或自行维修电池。
 危险	请勿挤压、刺穿或接触电池的金属端子。
 危险	请勿将电池置于高温环境或液体中。
 危险	如果不按照说明方法操作，可能导致操作者或他人遭受较大伤害。
 危险	请将电池存放在干燥阴凉的环境中。
 危险	如果电池损坏，请立即停止使用。

电池类型使用: AA电池

请按照以下步骤安装发射机电池:

1. 打开电池仓盖。
2. 将4颗电量充足的AA电池装入电池仓内，确保电池上的金属端子与电池仓内的金属端子接触。
3. 盖好电池仓盖。

低电量报警: 当电量低于4.2v时，面板上的G.LED慢闪报警提示。

操作指引



准备操作完成后，您可以按照本章指引开始使用本产品。

1、开机

请按照以下步骤进行开机:

1. 检查系统状态，确保：电池电量充足且安装正确。
2. 将开关拨到 [On] 位置，R.LED 灯常亮。
3. 连接接收机电源。

注意：为保障模型及人员安全，使用时请先打开发射机再给接收机上电。

 警告	此时系统已启动，请谨慎操作，否则可能导致产品损坏或人员伤亡。
 警告	为了您的安全请将发射机开关和油门打到安全位置。

2、对码（发射机和接收机在出厂前已对码成功。）

如需更换其他的发射机或接收机, 请按照如下步骤进行对码:

1. 按住对码按钮打开发射机进入对码模式。G.LED 将开始快速闪烁。一旦进入对码模式, 松开对码按钮。
2. 接收机上电自动进入对码;
3. 对码成功接收机 LED 指示灯慢闪, 发射机关机重启接收机指示灯常亮;

注意: 对码时请先将发射机进入对码状态, 再将接收机进入对码状态。

- 此对码步骤仅适用于 FS-G4P 发射机与 FS-R4P 接收机对码, 不同的接收机对码方式不同。
- 由于产品处于不断更新状态, 请进入 我们官网查询最新的发射机与接收机兼容表单。

3、遥感校准（该功能可以用于方向手轮和油门扳机的中位角度修正。）

发射机在出厂前已校准完成, 如需要重新校准, 请按照以下步骤执行:

1. 同步将手轮顺时针打到最大、扣机往前推到底并开机, 进入校准模式功能;
 - R.LED 和 G.LED 二闪一灭
2. 手轮校准: 操作手轮顺时针和逆时针转到最大最小;
 - R.LED 灭
3. 扣机校准: 往前往后推到最大最小;
 - G.LED 灭
4. 校准完成后按“BIND” 键退出并保存数据。

4、关机

请按照以下步骤进行关机:

1. 断开接收机电源。
2. 将开关拨到[OFF]位置, 使发射机关闭。



危险

关闭时, 请务必先关闭接收机电源, 再关闭发射机, 否则可能导致模型损坏、人员受伤。

系统功能

此章节主要介绍系统各项功能操作。

1、通道说明

该发射机共输出4个通道, 分配如下:

1. CH1: 方向手轮
2. CH2: 油门扣机
3. CH3: 三档开关
4. CH4: 复位按键

注意: CH4 按键开机默认输出 1000us, 按压操作一下通道值翻转 - 次, 数值在 1000us/2000us 之间互相切换。

2、通道反向（该功能用于调整舵机或马达的动作方向。）

按键ST.REV/TH.REV分别为CH1、CH2通道反向按键，开关上拨表示反向，下拨表示正常。

3、微调

ST.TRIM 为 CH1 方向微调，可复用为 CH3、CH4 微调，复用切换方式见 [5 模式切换]；
TH.TRIM 为 CH2 油门微调。

调节范围：-120us--+120us，微调步进为 4us；

ST.TRIM+/TH.TRIM+：增大微调值；

ST.TRIM-/TH.TRIM-：减少微调值。

LED指示情况：

操作一次微调键 G.LED 闪烁一次，长按快闪

当微调值位于中点时 G.LED 慢闪 2 下

当微调值位于两端时 (+120us/-120us)，微调无效且 G.LED 无指示（如微调值已调至 +120us，此时按 ST.TRIM+/TH.TRIM+ 键无效且 G.LED 无指示）

4、舵量调节

ST.D/R 为方向舵量调节，可复用为 CH2（油门）、CH3、CH4 舵量调节，复用切换方式见 [5 模式切换]；

调节范围：0-120%（默认 100%），步进为 5%；

ST.D/R+：增加舵量；

ST.D/R-：减小舵量

LED 指示情况：

操作一次按键 G.LED 闪烁一次，长按快闪

当比例值位于两端时 (0/100%)，按键无效且 G.LED 无指示（如比例值已调至 100%，此时按 ST.D/R+ 键无效且 G.LED 无指示）

5、模式切换

此功能用于将 ST.TRIM 及 ST.D/R 按键复用于其他通道（详见 [3 微调]、[4 舵量调节]）。

功能设置：正常开机状态下快速短按两下对码按键（BIND）（1S 内）即可循环切换模式一、二、三、四，开机默认为模式一。

模式一：G.LED 慢闪一次提示，ST.TRIM 为 CH1 微调，ST.D/R 为方向舵量调节；

模式二：G.LED 慢闪二次提示，ST.TRIM 为 CH1 微调，ST.D/R 为 CH2 舵量调节；

模式三：G.LED 慢闪三次提示，ST.TRIM 为 CH3 微调，ST.D/R 为 CH3 舵量调节；

模式四：G.LED 慢闪四次提示，ST.TRIM 为 CH4 微调，ST.D/R 为 CH4 舵量调节；

6、失控保护

此功能用于当接收机无法正常收到发射机的信号时，对应通道舵机移动至预先设定的位置，保护模型和操作人员的

功能设置 :发射机开机正常通讯状态下, 将需要设置的通道保持在需要设定的失控保护值位置保持不动, 同时长按对码键(BIND) 3S, G.LED 闪烁 2S 表示设置成功, 即当接收机无法接收信号后, 将按照设定的失控值输出。

注意: 失控保护出厂默认无任何设置, 无设置时失控接收机无有效信号输出。

7、初学者模式

初学者模式比较适合入门级玩家, 通过对油门幅度的控制来提高操作的安全性。

初学者模式模式油门输出仅为 50%, 即 CH2 通道范围默认为 1250~1500~1750us。

功能设置:

按住 CH4 按键, 同时方向手轮逆时针打到底 维持以上动作同时开机

注意: 出厂默认为正常模式, 开机时 G.LED 灯二闪一灭持续 3S, 代表此次进入初学者模式。

产品规格

1、发射机规格 FS-G4P

产品型号	FS-G4P
通道个数	4
适配模型	车、船
无线频率	2.4GHz
发射功率	<20dBm
无线协议	ANT
遥控距离	>300m(空旷无干扰地面距离)
通道分辨率	1024 级
电池	6V DC 1.5AA*4
充电接口	无
续航时间	依电池类型
低电压报警	<4.2V
天线类型	内置单天线
数据接口	无
温度范围	-10°C ~ +60°C
湿度范围	20-95%
在线更新	无
遥控器颜色	黑
外形尺寸	160*193*97mm
机身重量	220g
认证	CE, FCC ID:N4ZG4P00

接收机概览

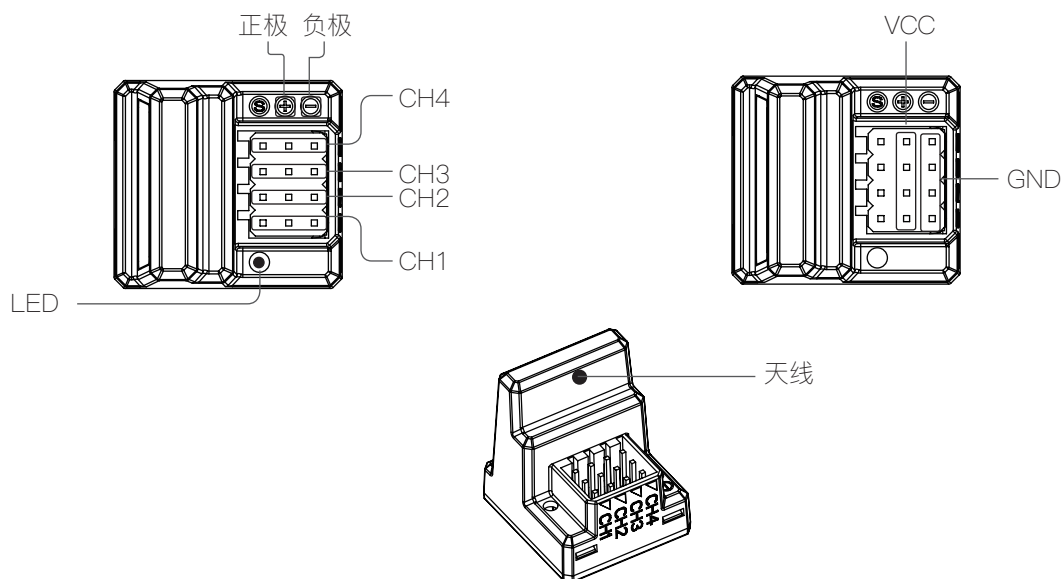

注意

为保证信号质量，天线应与模型机身保持垂直，且天线竖立摆放。

1、接收机规格 FS-R4P

产品型号	FS-R4P
PWM 通道	4
无线频率	2.4GHz
无线协议	ANT
遥控距离	>300m (空旷无干扰地面距离)
天线类型	内置单天线
电源	3.5-8.4V
RSSI	无
数据接口	PWM
温度范围	-10°C—+60°C
湿度范围	20—95%
在线更新	无
外形尺寸	22.6*20.6*25.5mm
机身重量	6g
认证	CE, FCC

油门扳机位置

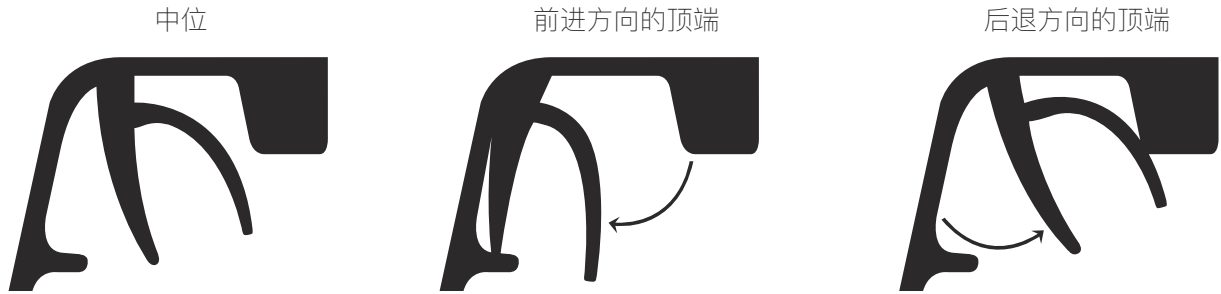

型号	WP-1040-BRUSHED WP-1040-BRUSHED-Crawler&Boat *	
正向持续/峰值电流 (10秒) 反向持续/峰值电流 (10秒)	40A / 180A 20A / 90A	
支持电压范围	2-3节锂电 (Lipo) 或 5-9节镍氢 (NiMH) 电池	
主要适用车型	普通版: 1/10 电房、电越、短卡、大脚、卡车 攀爬/船用版: 1/10 攀爬车、坦克及各种模型船	
支持电机 T数	2节锂电 5或6节镍氢	540或550尺寸电机≥12T 或RPM低于30000 @7.2V
	3节锂电 7或9节镍氢	540或550尺寸电机≥18T 或RPM低于 20000 @7.2V
内阻 (单桥臂)	正转0.002欧姆, 反转0.004 欧姆	
BEC输出	6V/2A (线性稳压BEC)	
尺寸 (mm)	WP-1040-BRUSHED:46.5*34*28.5 WP-1040-BRUSHED-Crawler&Boat:46.5*34*28.5	
重量	WP-1040-BRUSHED:65g WP-1040-BRUSHED-Crawler&Boat:70g	

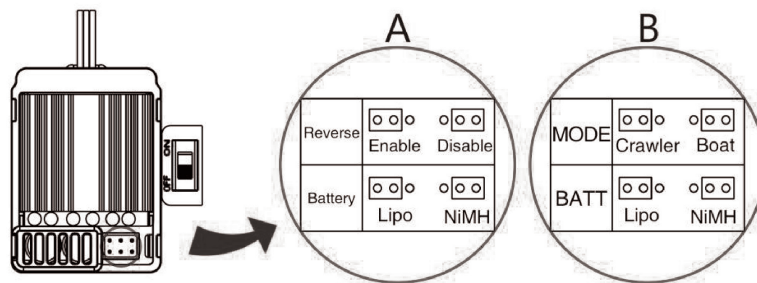

A:WP-1040-BRUSHED
B:WP-1040-BRUSHED-CRAWLER & BOAT

故障现象	可能原因	解决方法
上电后指示灯不亮，不自检，无鸣音。	1. 电调没有得到工作电源。 2. 电调开关损坏。	1. 检查电池到电调的电源输入通路是否有焊接不良情况，并重新焊好。 2. 更换电调开关。
上电后红色LED 闪烁，电机无法启动。	1. 电调油门线插反或通道插错。 2. 电调无法完成油门自检校调。	1. 将电调的油门排线按正确方向插到接收机的油门通道（Throttle, 通常为CH2）。 2. 将遥控器的油门通道的中点微调“TRIM”调为0 或相应旋钮调到中点位置。
遥控器做前进操作，车子反而倒退。	1. 遥控器油门通道方向设置错误或马达接线错误。	1. 将马达的两条线互换。 2. 将遥控器油门通道反向，从原“NOR”换为“REV”或从原“REV”换为“NOR”。
车子无法达到全速，油门打到最大，红灯不恒亮。	1. 遥控器设置错误。	1. 将遥控器油门通道的“D/R”、“EPA”、“ATL”等参数调到100%或相应旋钮调到最大位置，油门通道的中点微调“TRIM”调为0 或相应旋钮调到中点位置。
车子无法倒车。	1. 倒车选项跳线帽位置错误。 2. 油门中点偏移。	1. 将倒车选项跳线帽插入正确位置。 2. 将遥控器的油门通道的中点微调“TRIM”调为0 或相应旋钮调到中点位置。
车子正向加油不走，反向倒车却行走。	1. 遥控器油门通道方向设置错误。	1. 将遥控器油门通道反向换，从原“NOR”换为“REV”或从原“REV”换为“NOR”。
电机转动过程中，突然停转。	1. 油门信号丢失。 2. 电调进入电池低压保护或过热保护状态。	1. 检查遥控器电池电压是否过低。 2. 电调红灯闪烁表示低压或过热保护，请更换电池组或检查电调温度。
车子无法前进也无法倒车，指示灯正常。	1. 电调和马达之间的连接中断。 2. 马达损坏。	1. 检查马达和电调之间的接头，确保连接可靠。 2. 更换新马达。
电机启动时急加速，电机有卡住或停顿的现象。	1. 电池放电能力不够。 2. 电机转速过高，齿轮比搭配过于激进。 3. 车子传动系统有问题。	1. 更换放电能力强的电池。 2. 更换低速电机，或将减速比提高。 3. 检查车架传动系统是否顺畅。

车辆操作

步骤1：打开发射器，发射器前灯会闪亮，进入对频模式。

步骤2：打开接收器开关，车前灯会闪亮，进入对频模式。

步骤3：当发射器、接收器对上频成功时，发射器前灯会长亮，车前灯会关闭。

电池注意事项

- 不要使用NiCd、NiMH或任何其他类型的充电器给LIPO锂聚合物电池充电。请使用LIPO锂聚合物的专用充电器给LIPO锂聚合物电池充电。
- 请勿在无人看管的情况下充电。
- 电池请勿过充。
- 请勿将电池置放在易燃、不耐热的表面上充电。
- 总是使用安全袋或安全容器给电池充电。保证电池在任何时候都不过热。电池温度超过140华氏度（60度）则易造成损坏，甚至引发火灾。
- 请勿将电池长期置于模型产品内，更勿在模型产品内直接充电。
- 请勿给电池放电，以免损坏电池。
- 任何时候请勿将电池暴露在水或湿气之中。
- 请勿在明火或加热器附近存放电池。

- 请勿与其他未组装或预组装的电池混用。
- 需将电池存放在远离儿童的安全位置。
- 模型如出现任何碰撞，需立刻拆除电池。
- 即使出现微小的损坏，也需仔细检查电池和连接器。
- 注意：使用后电池可能会发热，需让电池冷却到室温后再进行充电。
- 请勿让电解液接触眼睛或皮肤。如电解液不慎接触到身体的任何部位，请立即进行清洗。请勿替换或修改电池组的连接器或电线。
- 在进行充电或其他任何操作之前需检查电池的状况。
- 请勿造成电池短路。
- 请勿直接接触已泄漏或已损坏的电池。
- 请勿超出建议温度范围充电电池（0度-45度）。

电池充电

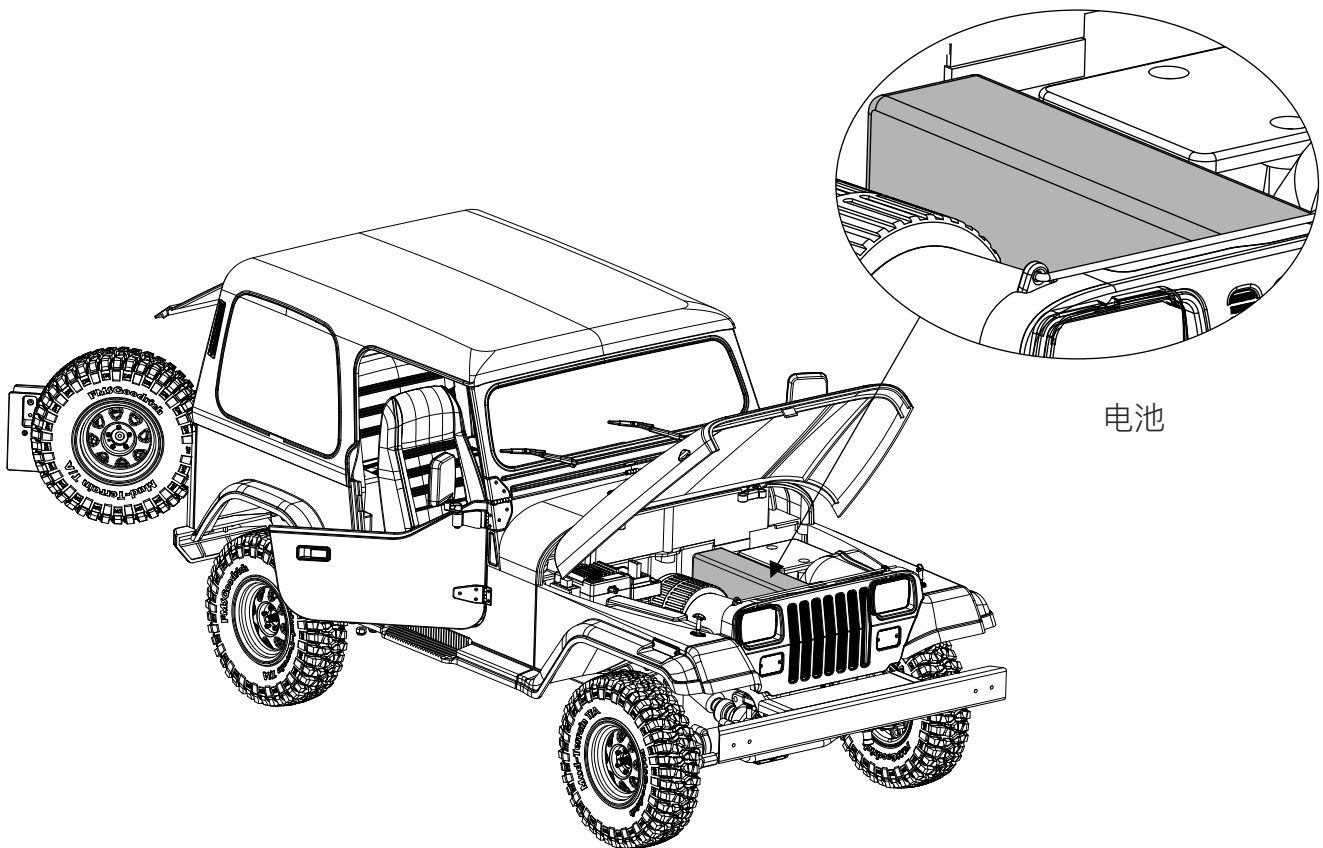

警告

1. 如果长时间不使用本产品，请断开电池连接，并将电池取出，以防漏液。
2. 给电池充电之前，请务必保证电池已断开连接，并已从车辆上取下。
3. 不要打开、拆解或试图维修电池。

C1011	驱动牙箱组散件	C1418	螺母包
C1010	传动轴品成	C1419	销针
C1391	中传动牙箱品成	C1420	轴承包
C1021	12mm 车轮6角件	C1421	限滑器弹簧
C1392	攀爬轮胎	C1422	限滑片
C1393	攀爬车轮	C1423	大齿42T 0.6
C1394	11033 前桥成品	C1424	5.8波头
C1395	11033 前桥胶件	C1425	齿轮套装
C1396	11033 前避震器总成(一对)	C1080	35T 有刷550电机
C1397	11033 后避震器总成(一对)	C1081	垫圈
C1398	转向C座件	C1426	前轮传动总成
C1399	转向连杆	C1427	驱动杯套装
C1400	11033 后桥成品	C1428	金属转向C座件
C1401	后轮轴	C1084	套筒介子
C1402	11033 后桥胶件	C1429	金属转向支架
C1403	11033 窗框	C1430	马达齿
C1404	11033 雨刷	C1101	五金传动轴成品
C1405	11033 座椅	C1105	2.4G 发射器碳纤纹风格
C1406	11033 前防撞	C1106	2.4G 发射器碳纤纹风格 + 接收器
C1407	11033 后防撞	C1035	9克舵机
C1408	11033 高清镜	C1431	11033 灯线
C1409	11033 灯片	C1108	防水40A电调
C1410	11033 车尾门	C1335	2.4G 接收器
C1411	11033 车尾连杆	C1432	11033 车壳
C1412	11033 档杆	C1433	11033 灯杯
C1413	11033 方向盘套件	C1434	11033 车门
C1414	11033 车头盖	C1435	11033 车门
C1415	11033 锁件	C1436	11033 车顶盖
C1416	11033 防滚架	C1437	11033 仪表盘
C1417	11033 备胎架	C1438	11033 螺丝包
C1009	连杆波帽		

Open the tailgate and rear window in the following order:

1. Use a Phillips head screwdriver to remove the screw and remove the spare tire.
2. Pull the tailgate open.
3. Lift the rear window.

Close the tailgate and rear window in the following order:

1. Snap on the tailgate closed.
2. Snap the rear window closed.
3. Install the spare tire using a Phillips head screwdriver.

请按照以下顺序打开尾门和后车窗：

1. 使用十字头螺丝刀取出螺丝拆下备胎。
2. 拉开尾门。
3. 掀起后车窗。

请按照以下顺序关闭尾门和后车窗：

1. 扣合尾门。
2. 扣合后车窗。
3. 使用十字头螺丝刀装好备胎。

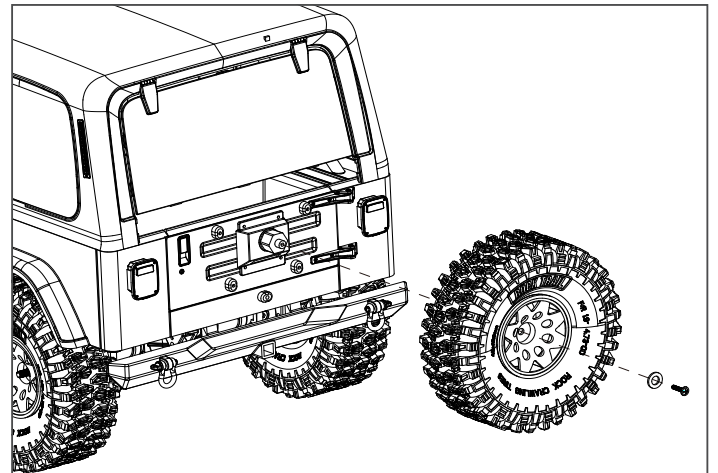
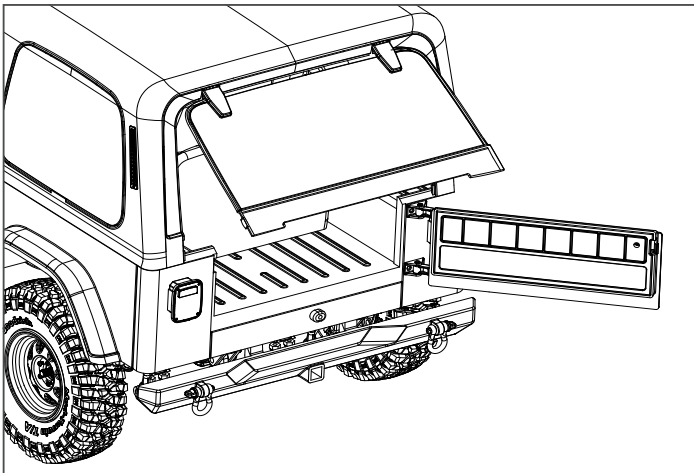

Use CM2X8 screws with M2 nuts

用CM2X8螺丝 配合M2螺母

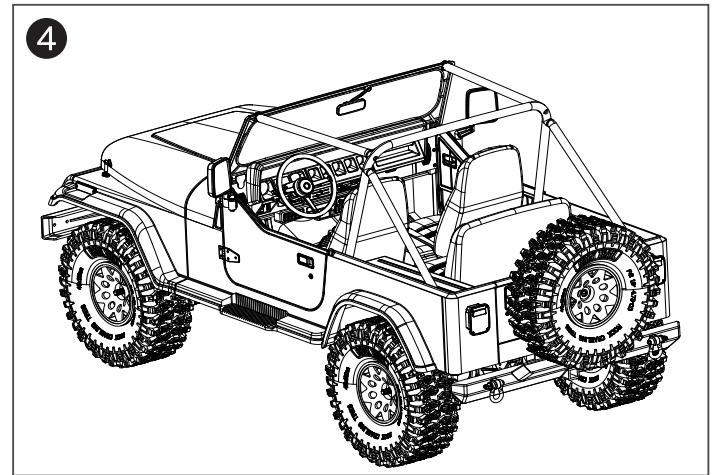
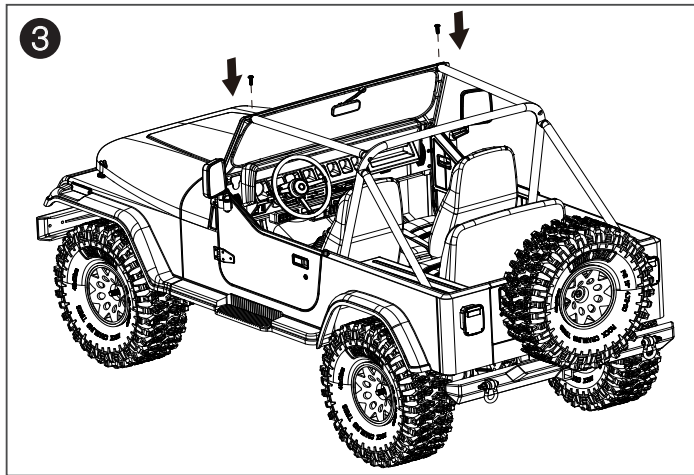
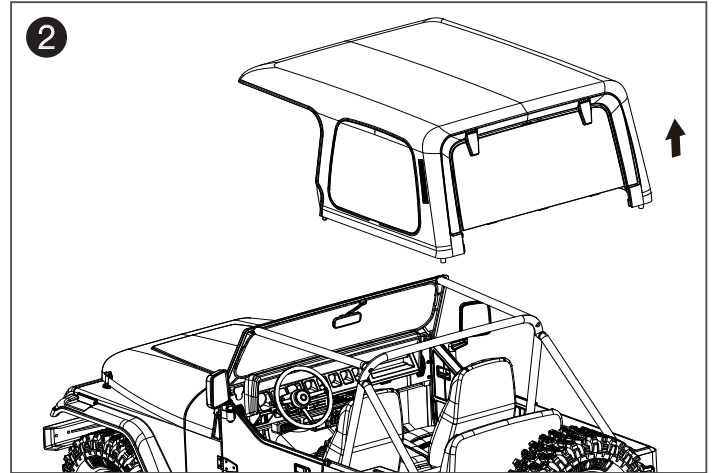
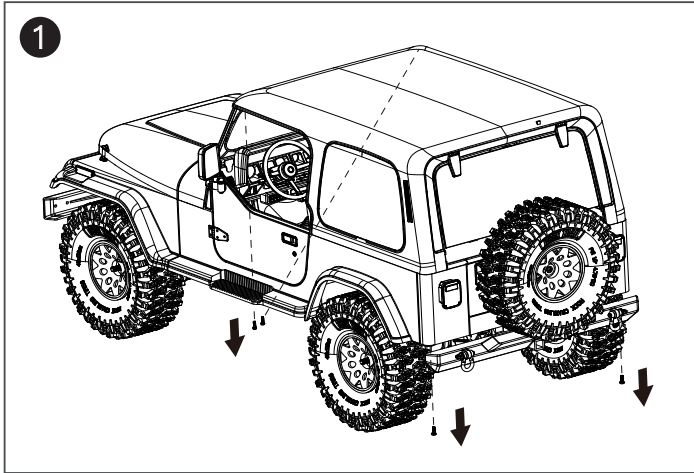

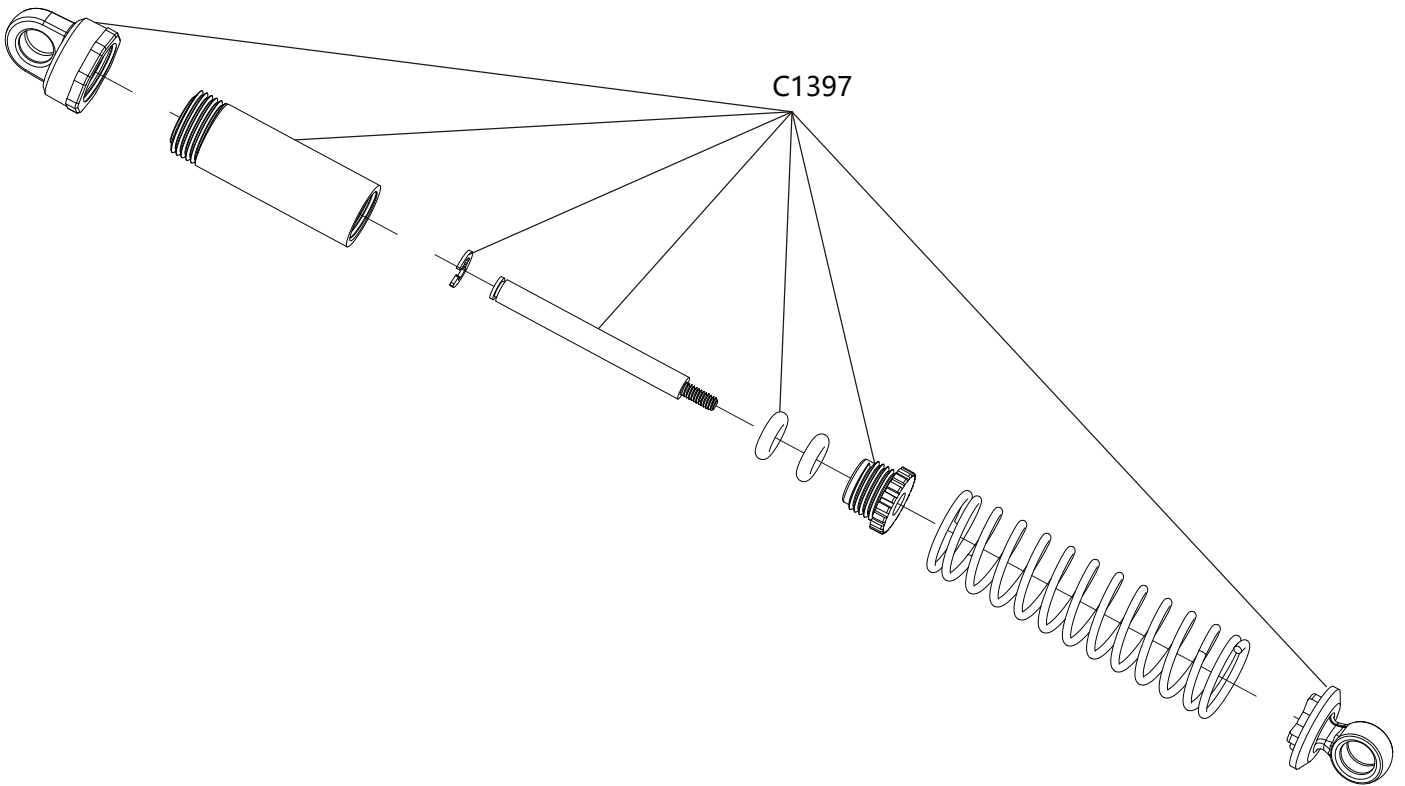
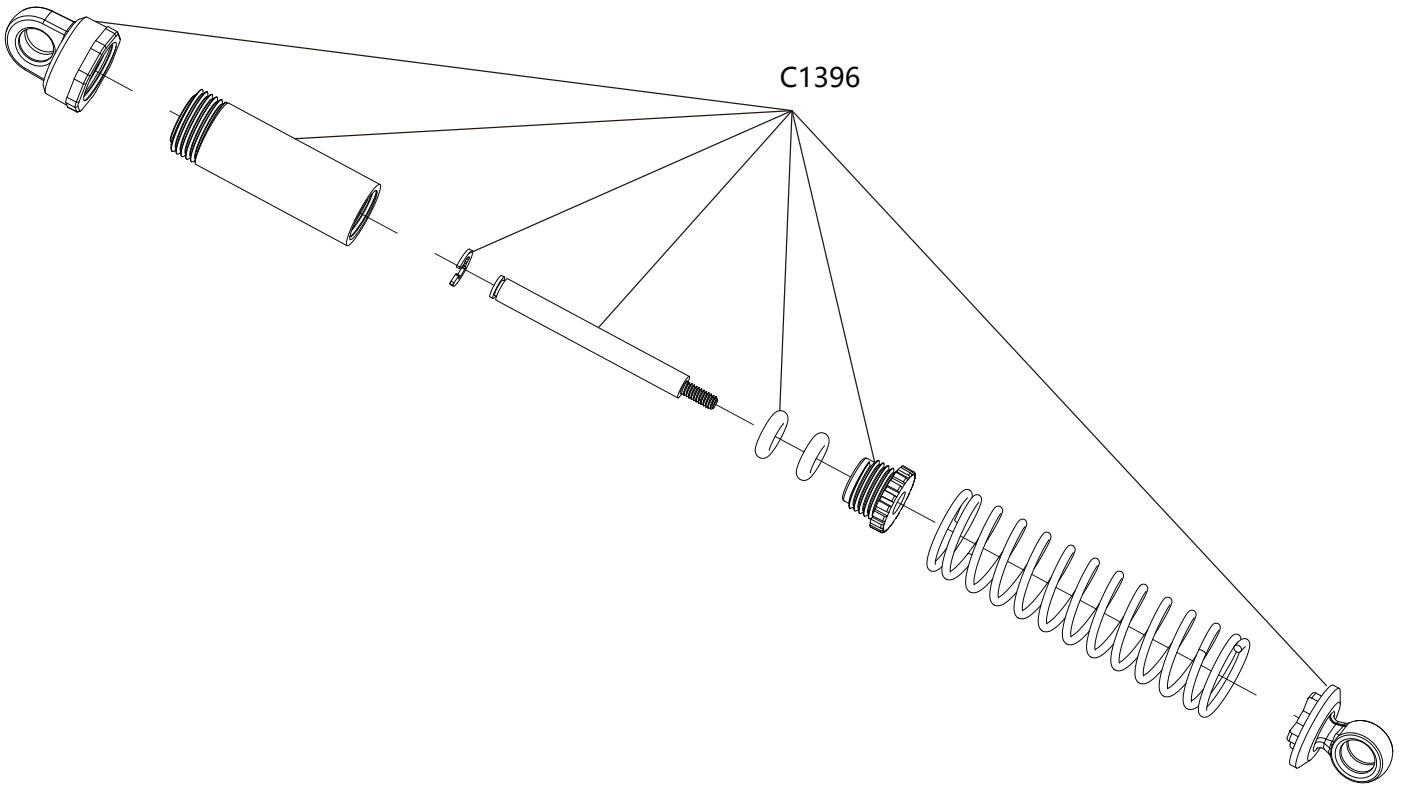

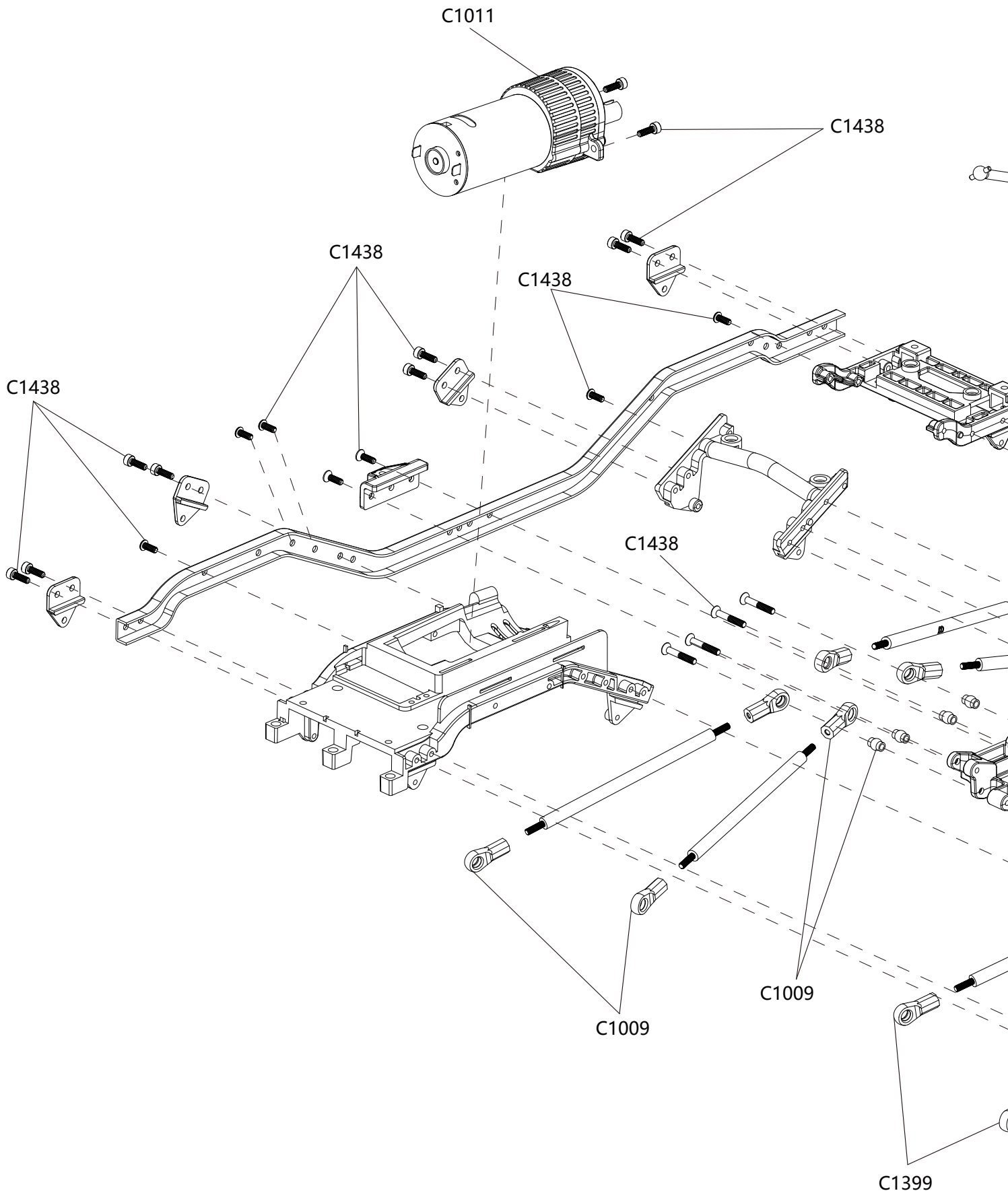

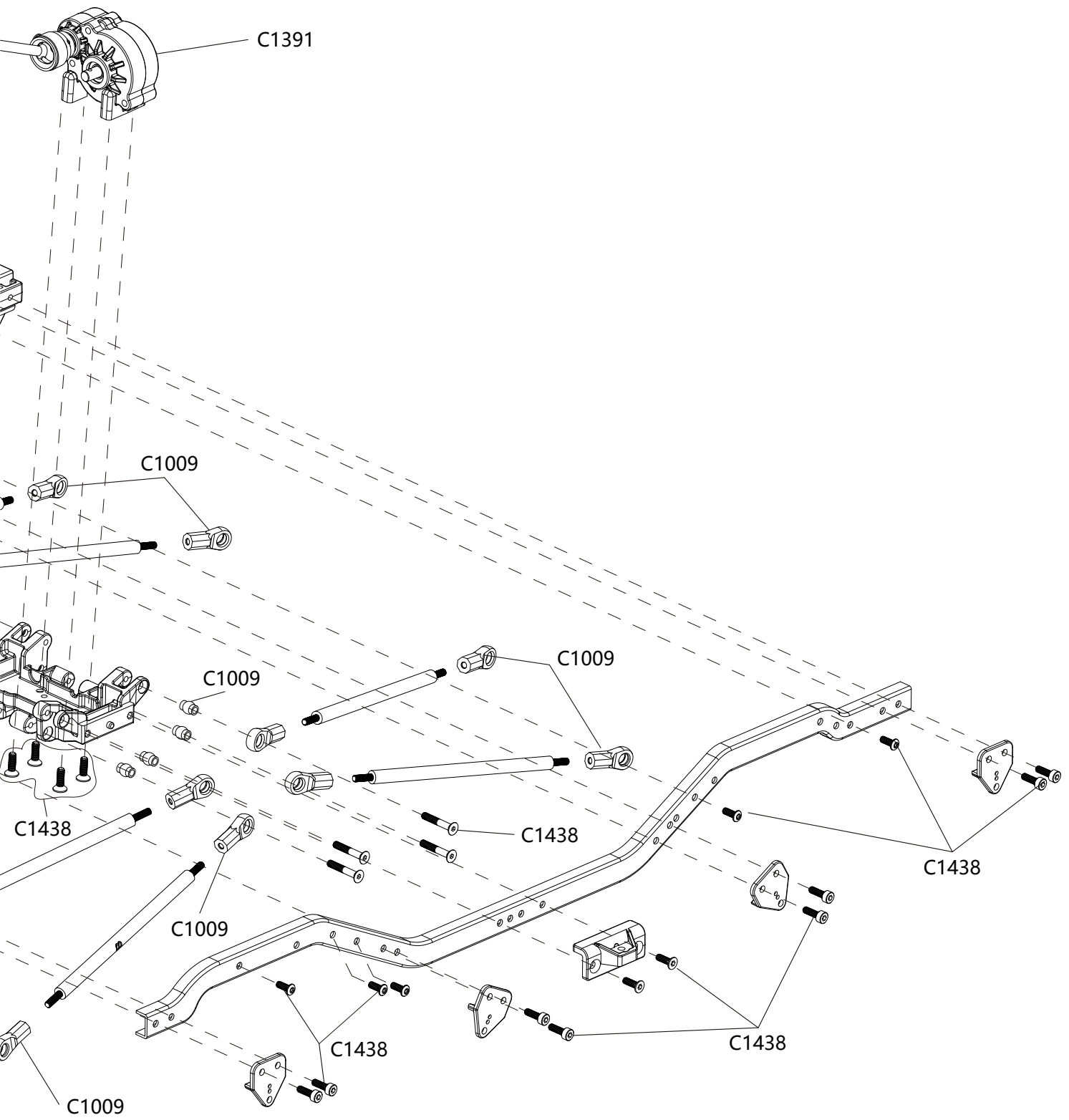

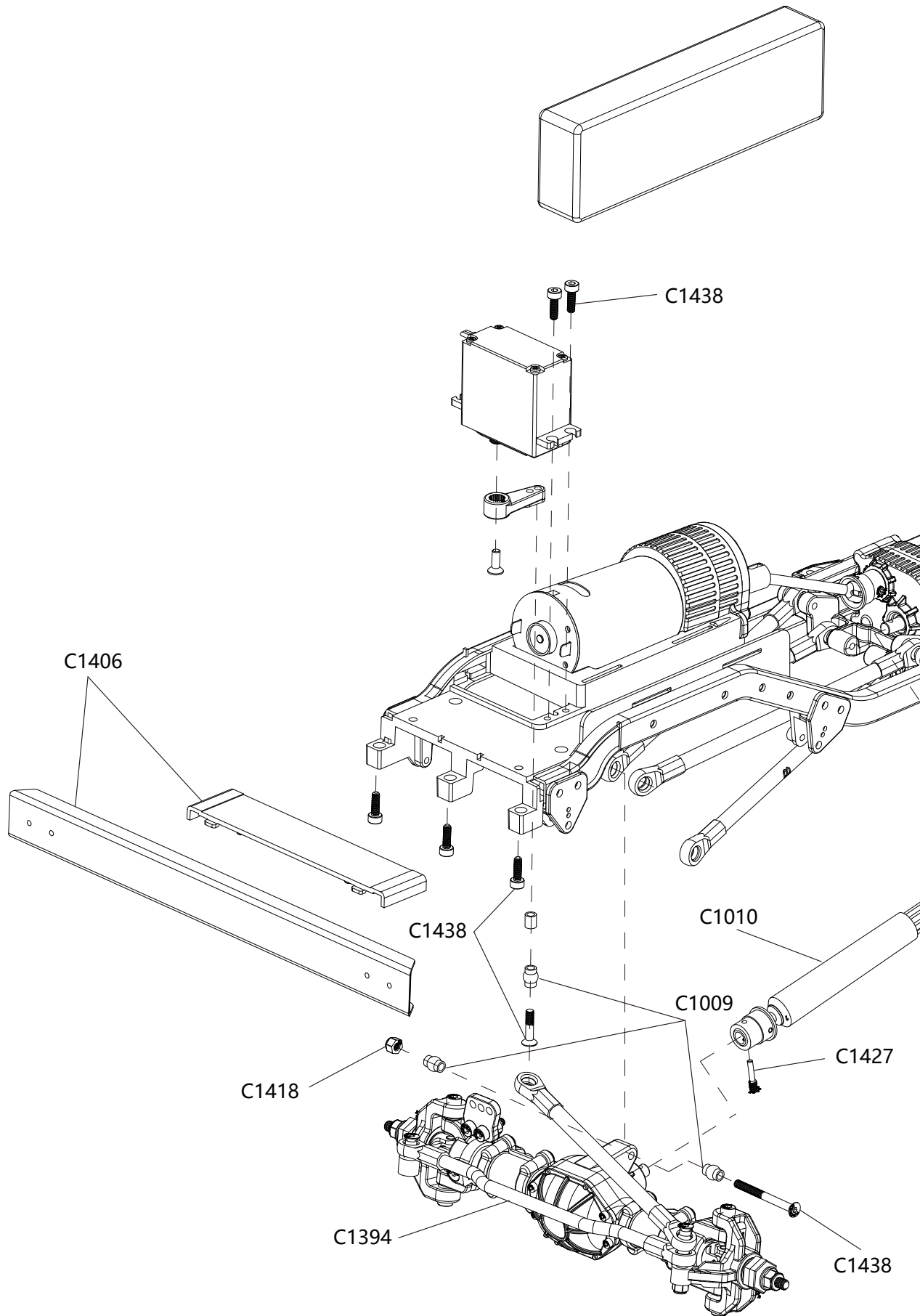

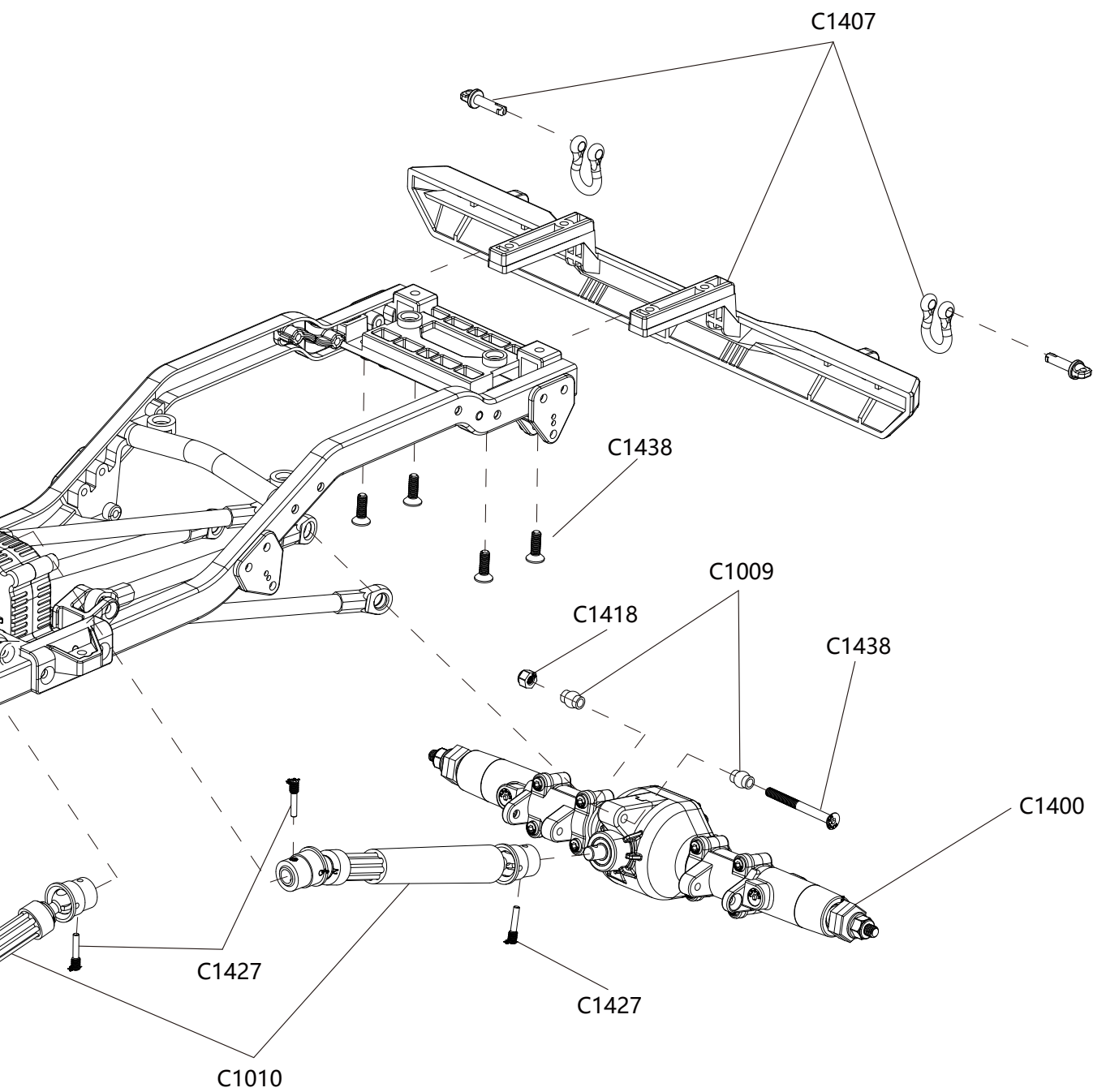

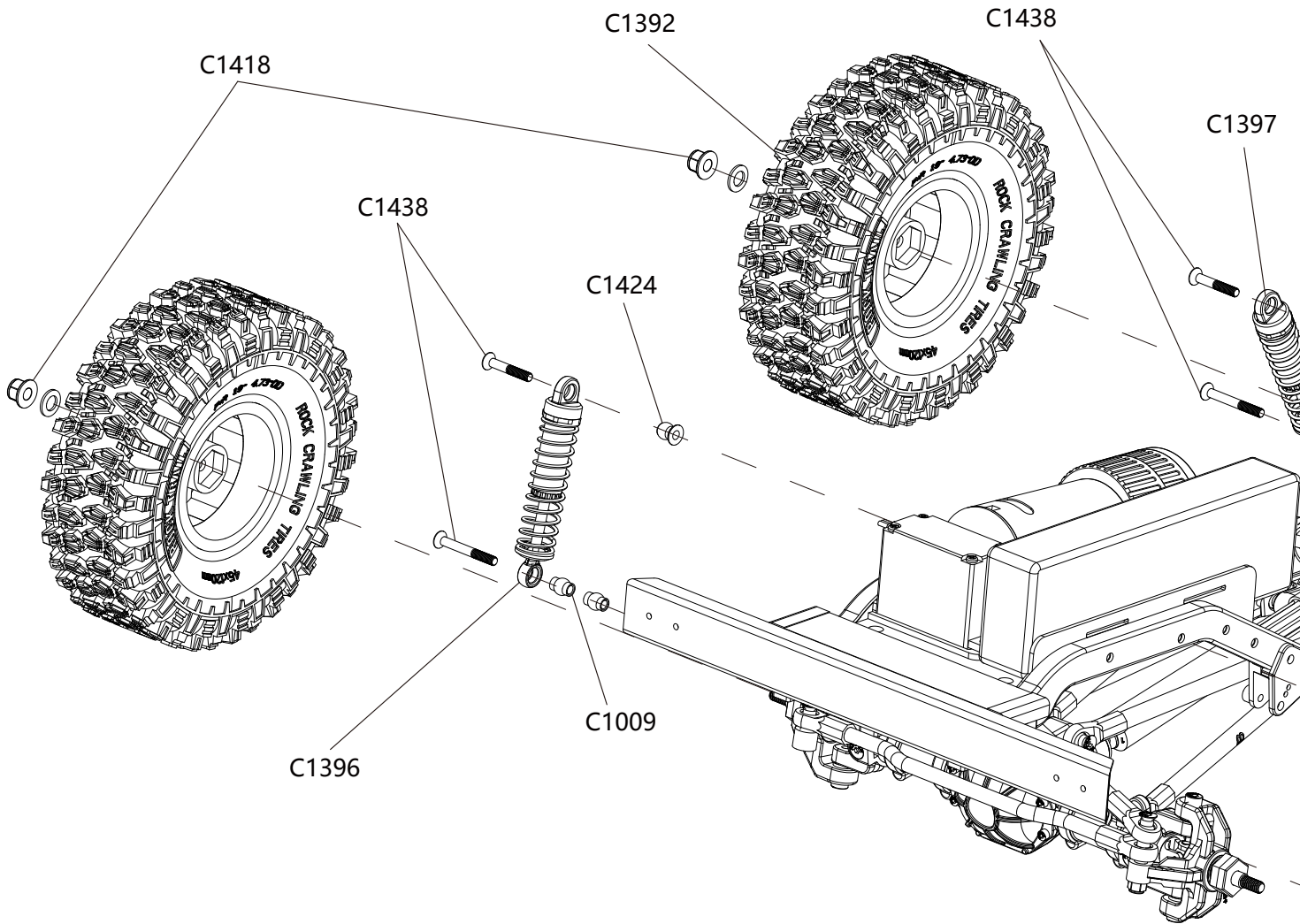

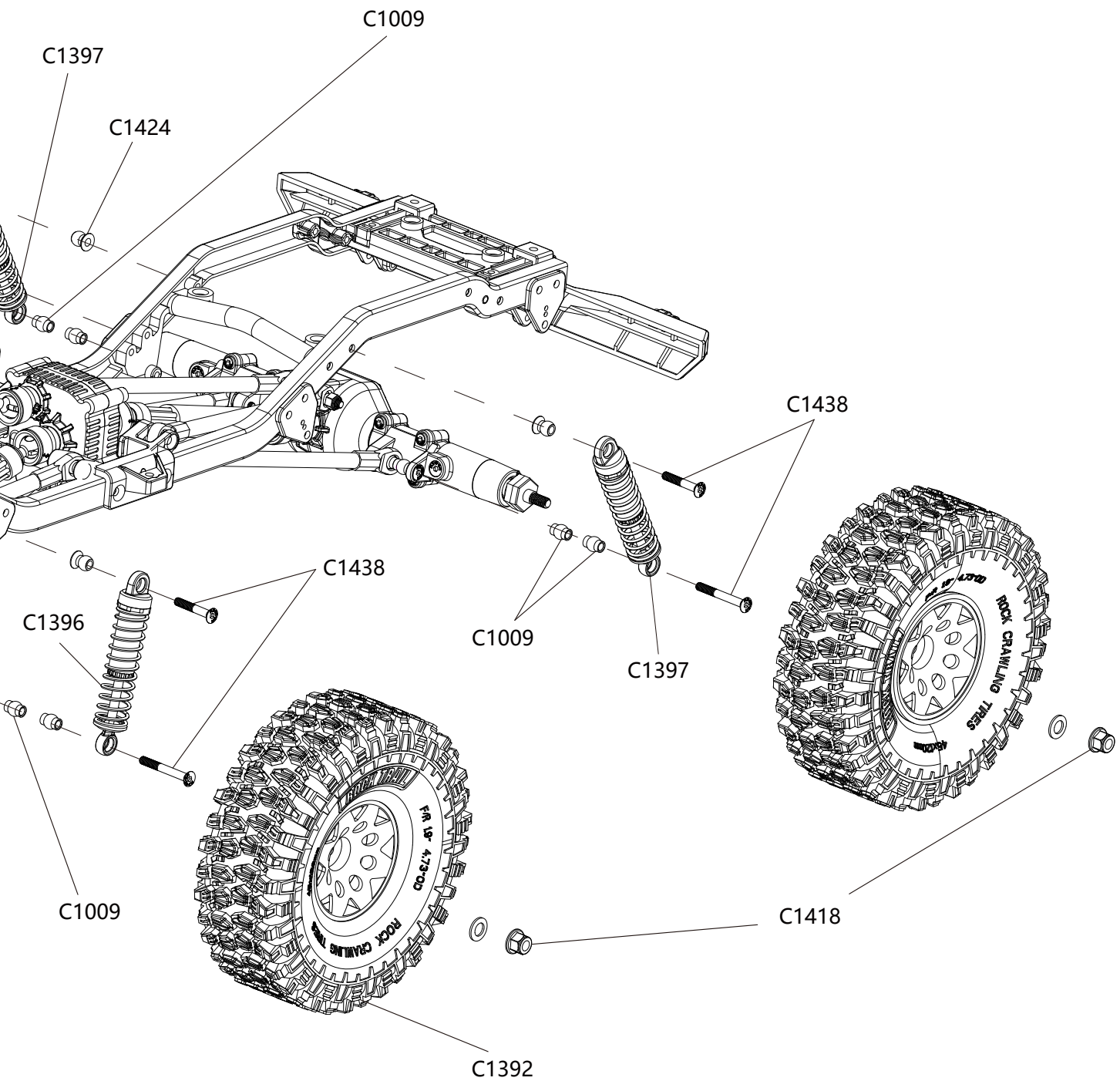

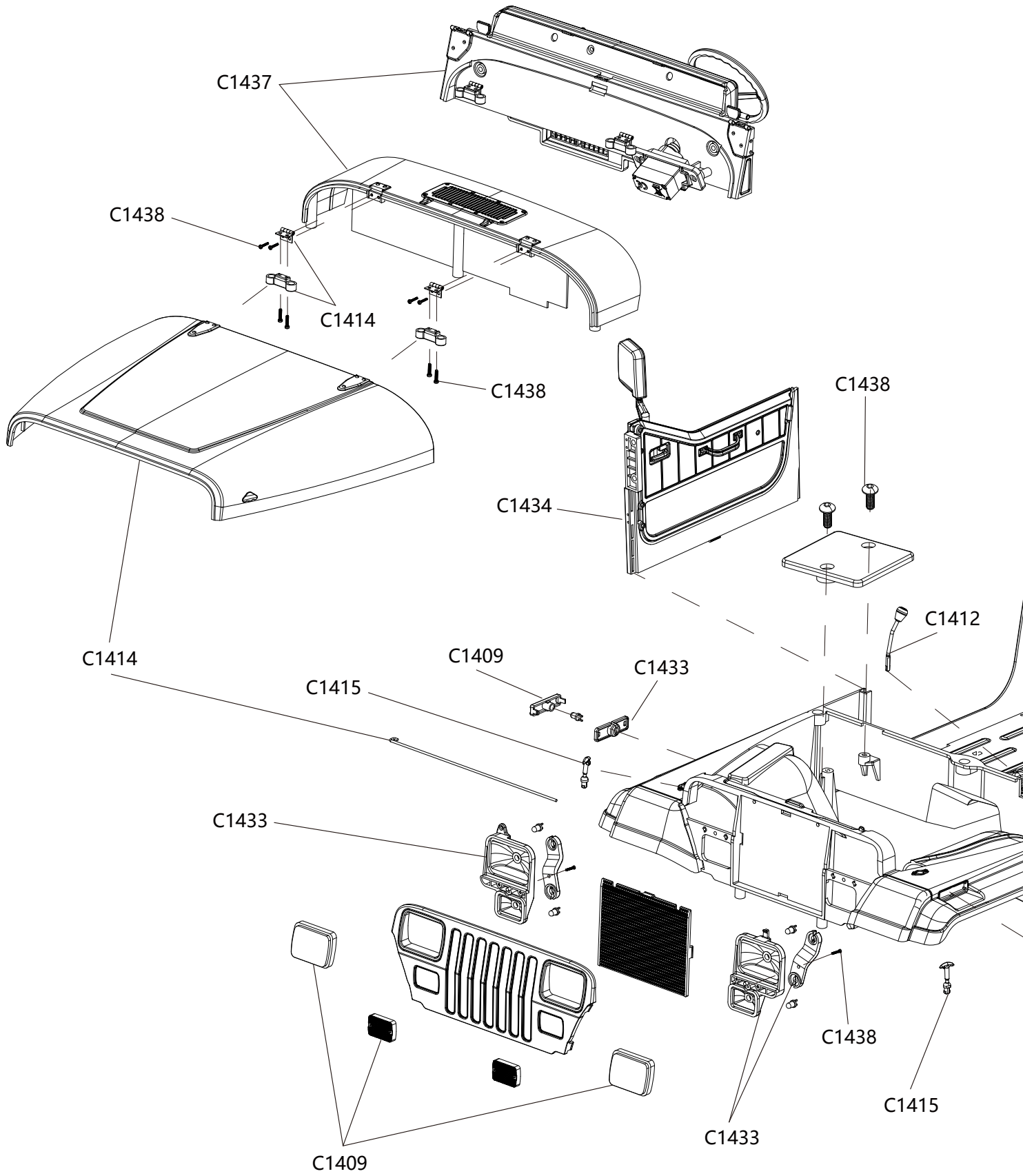

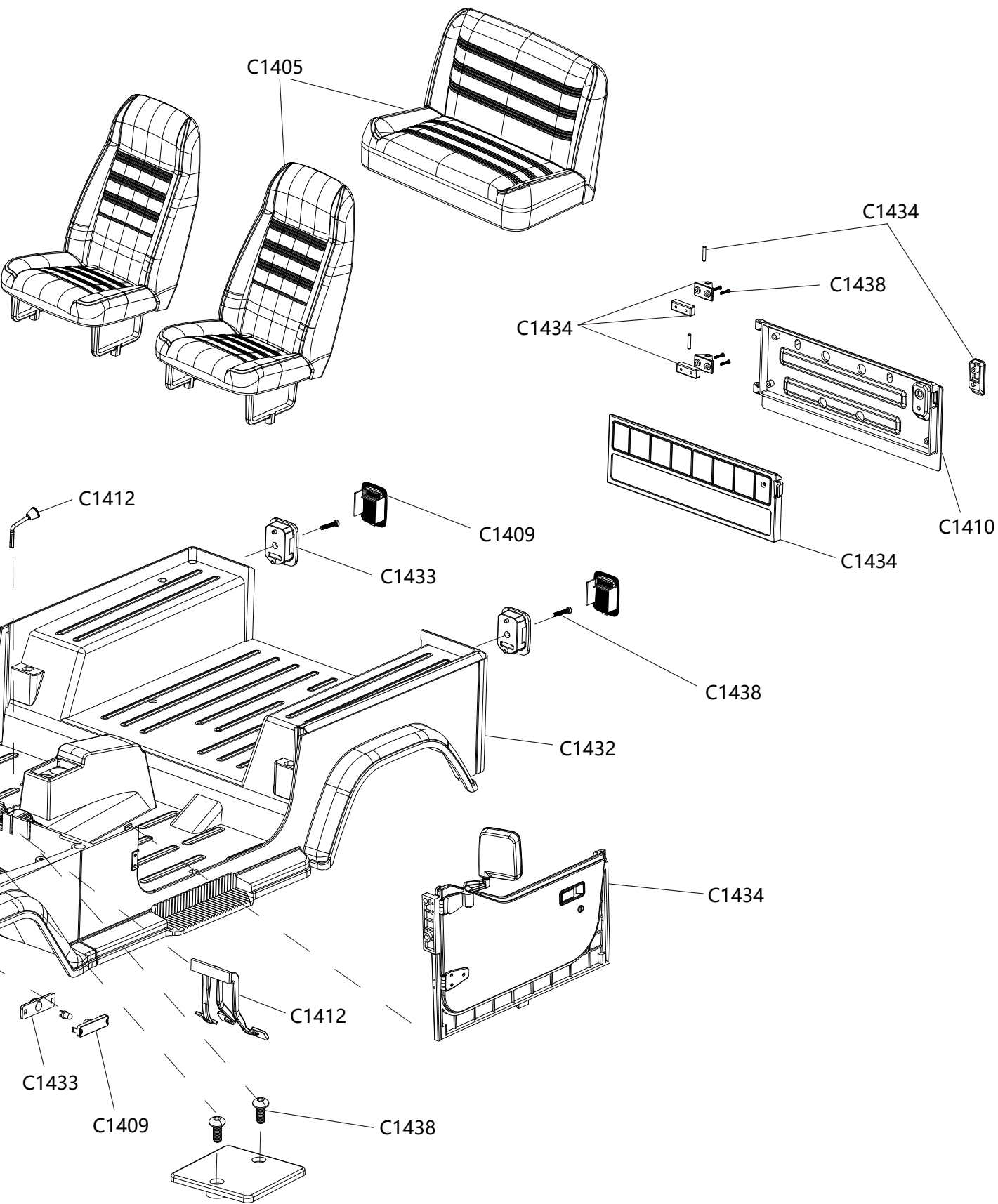

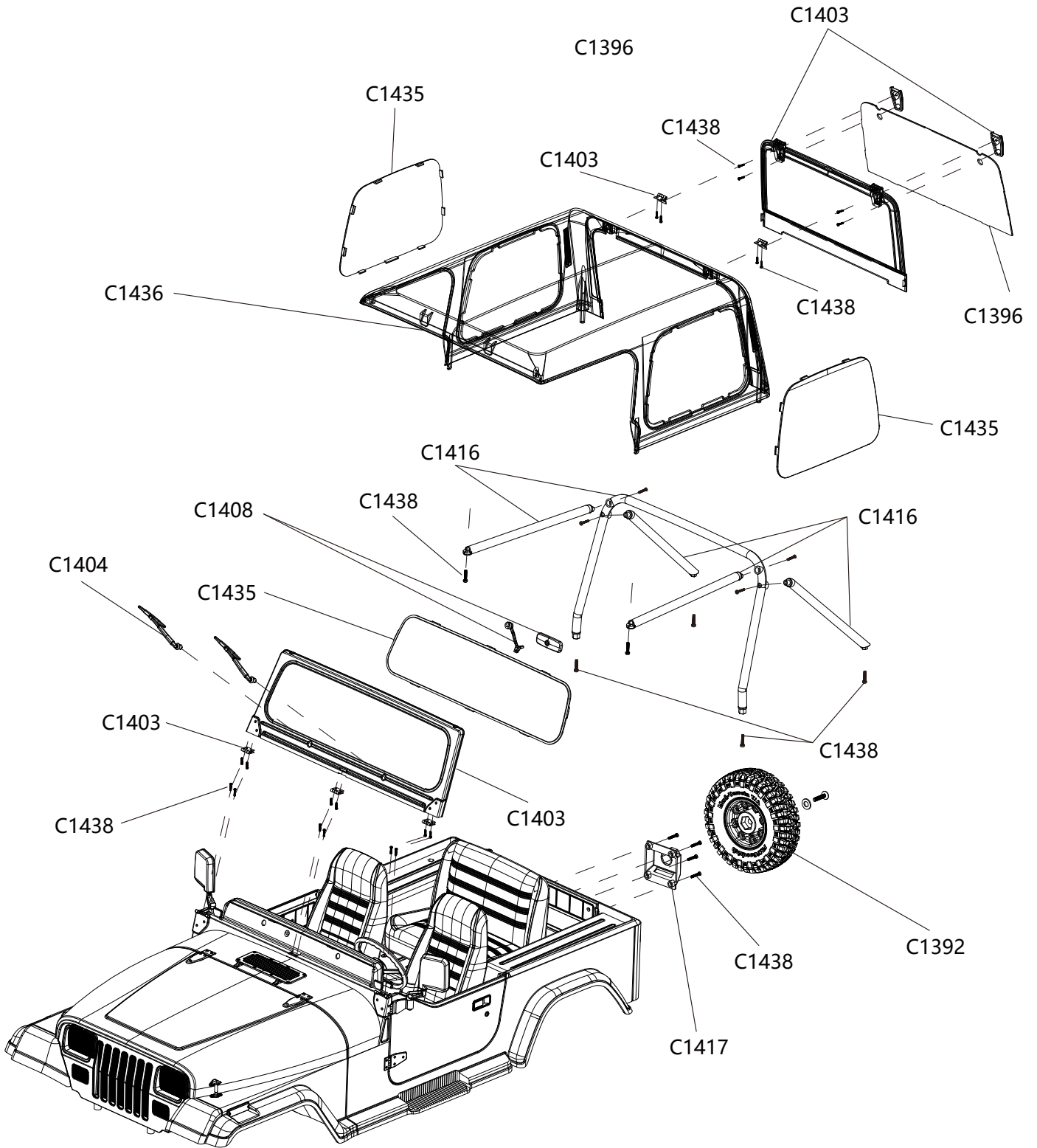

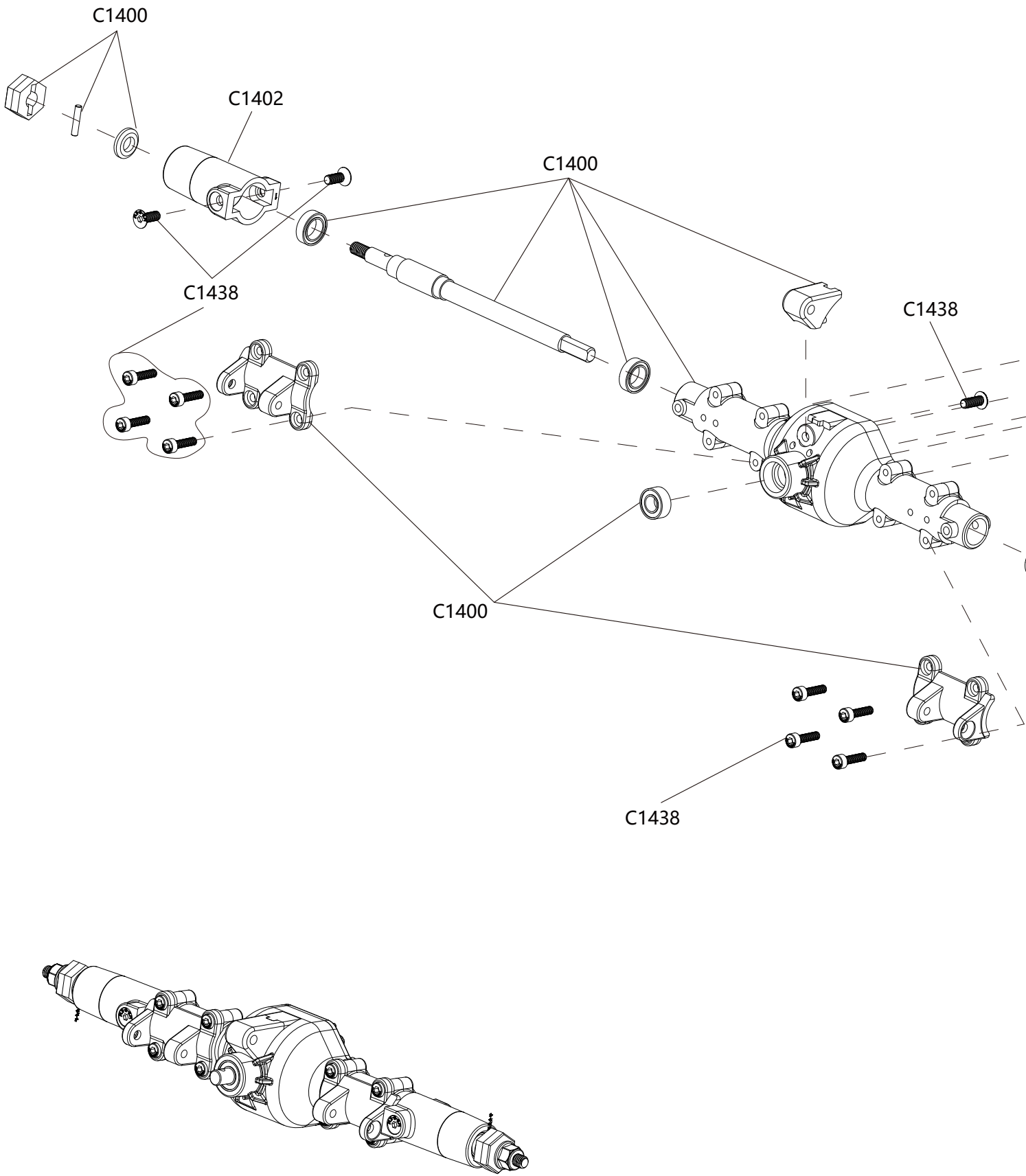

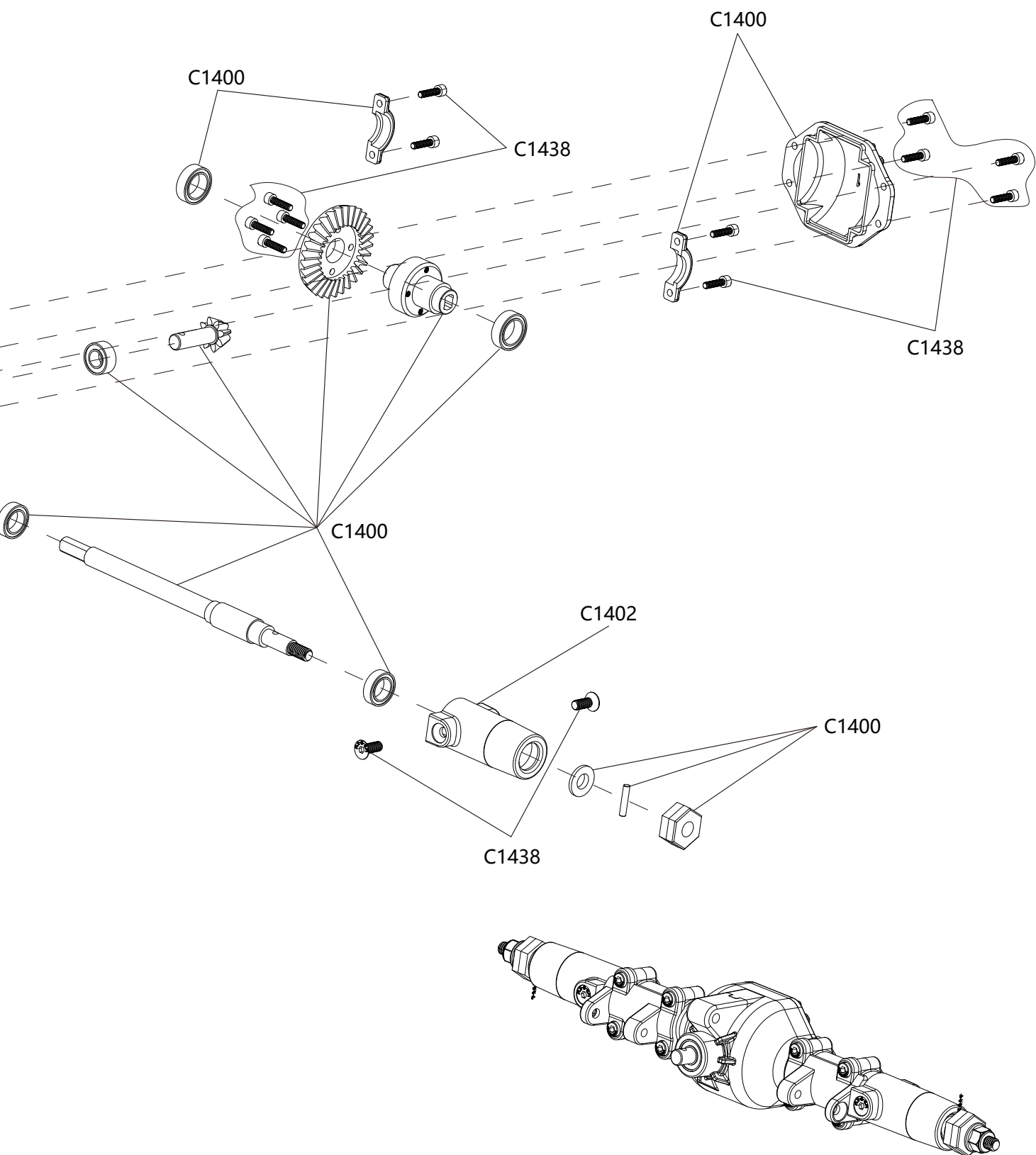

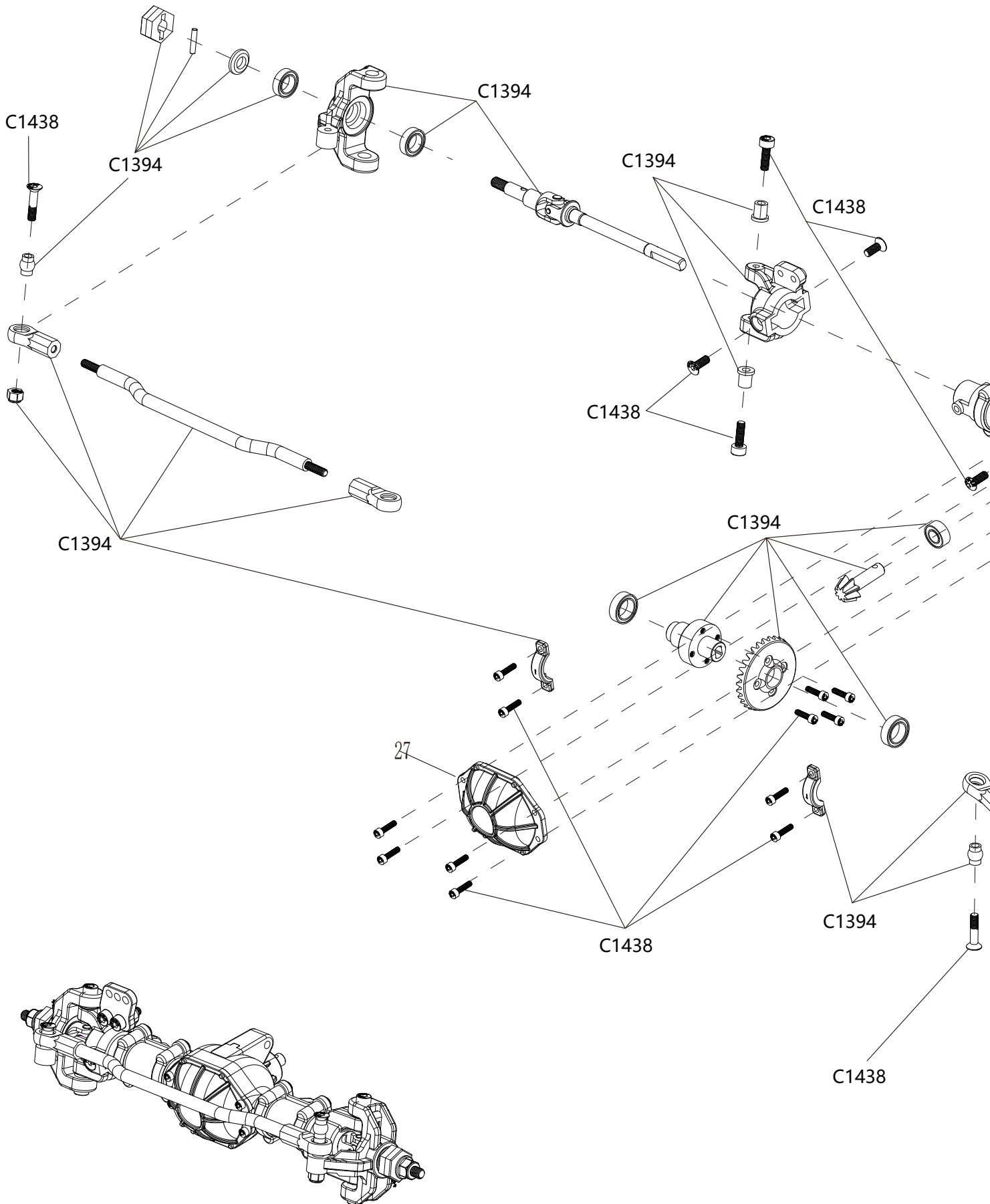

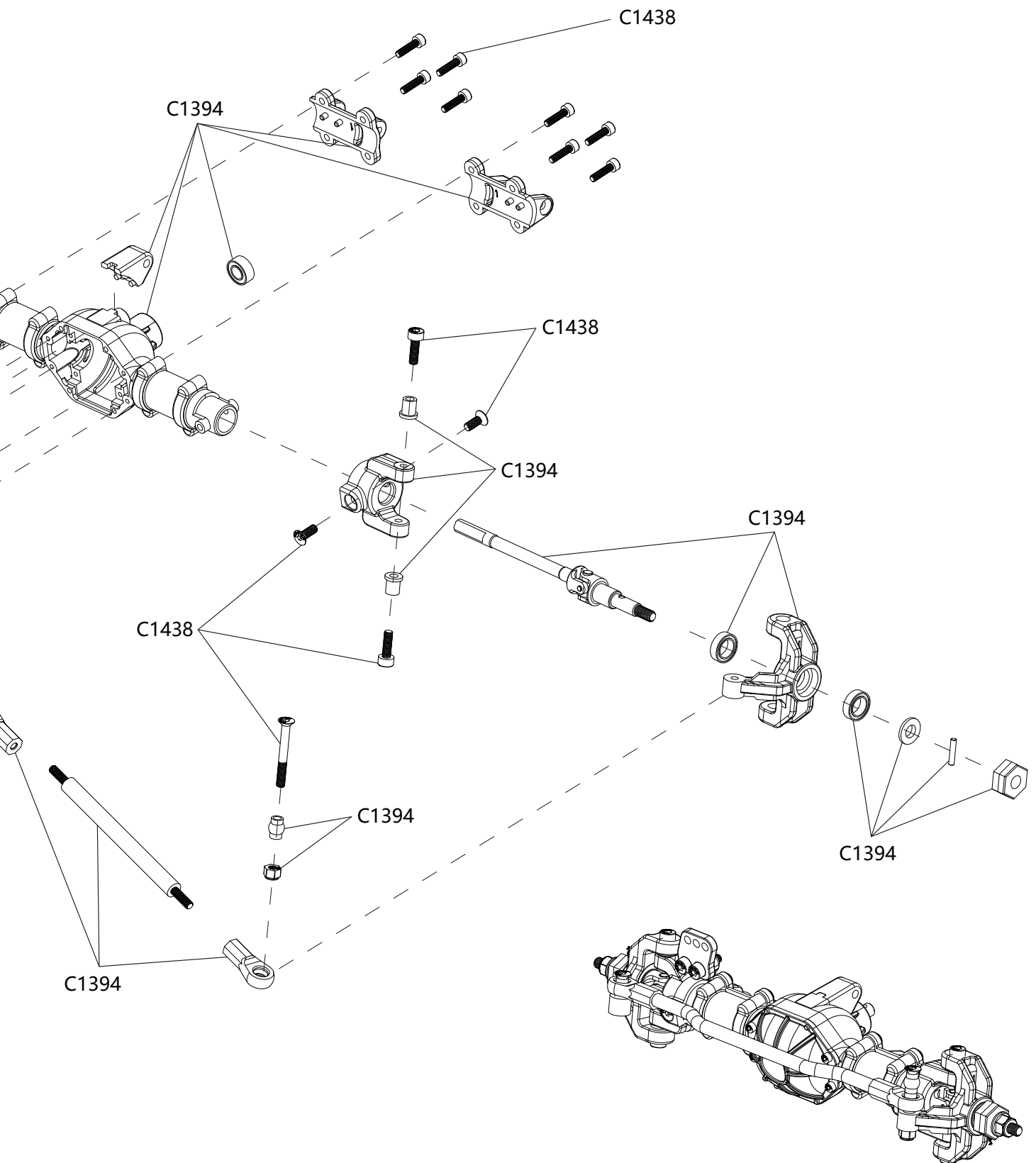

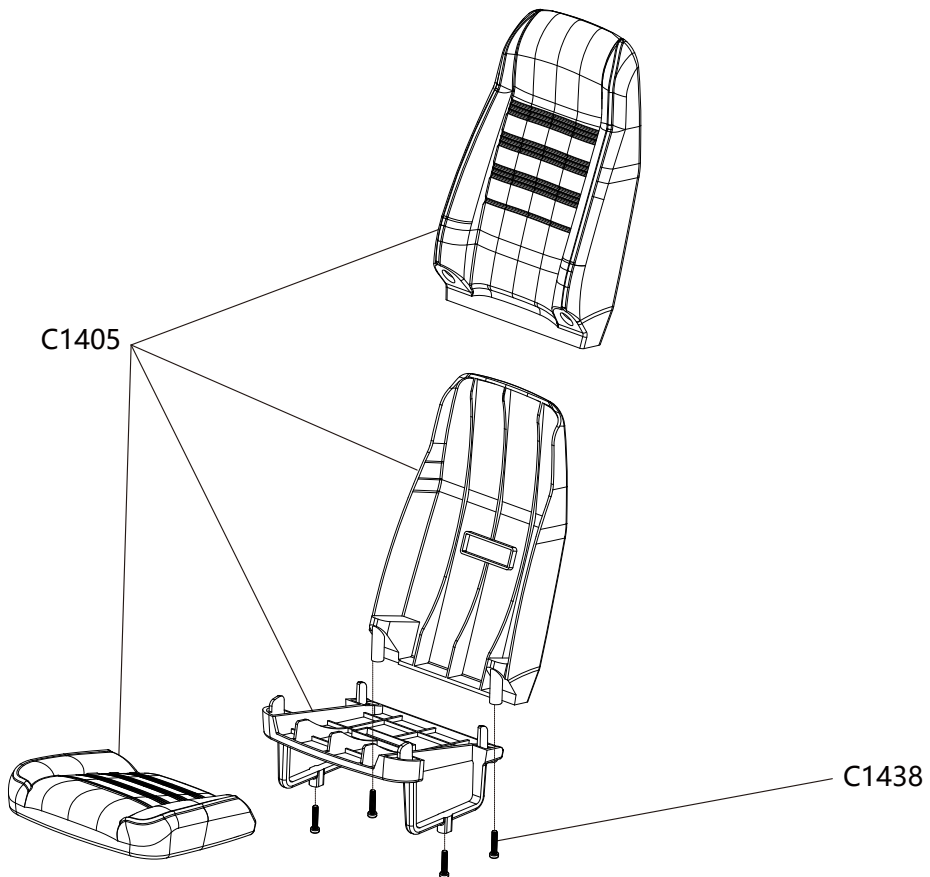
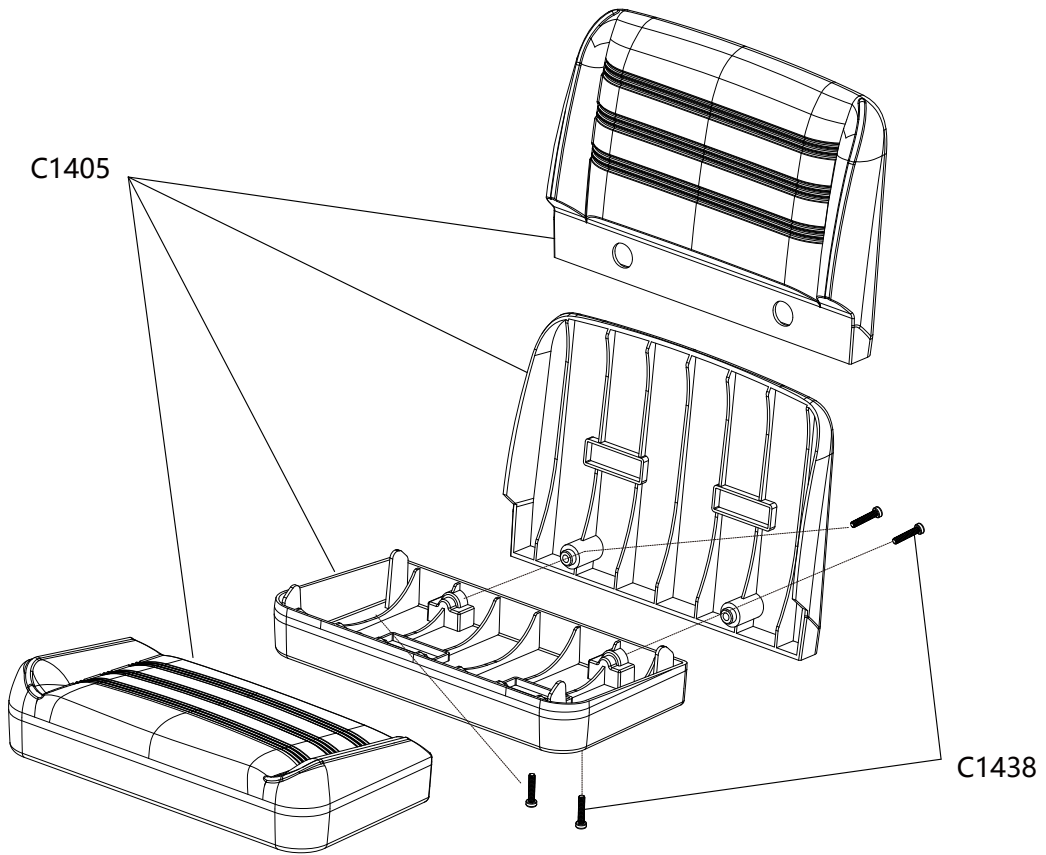

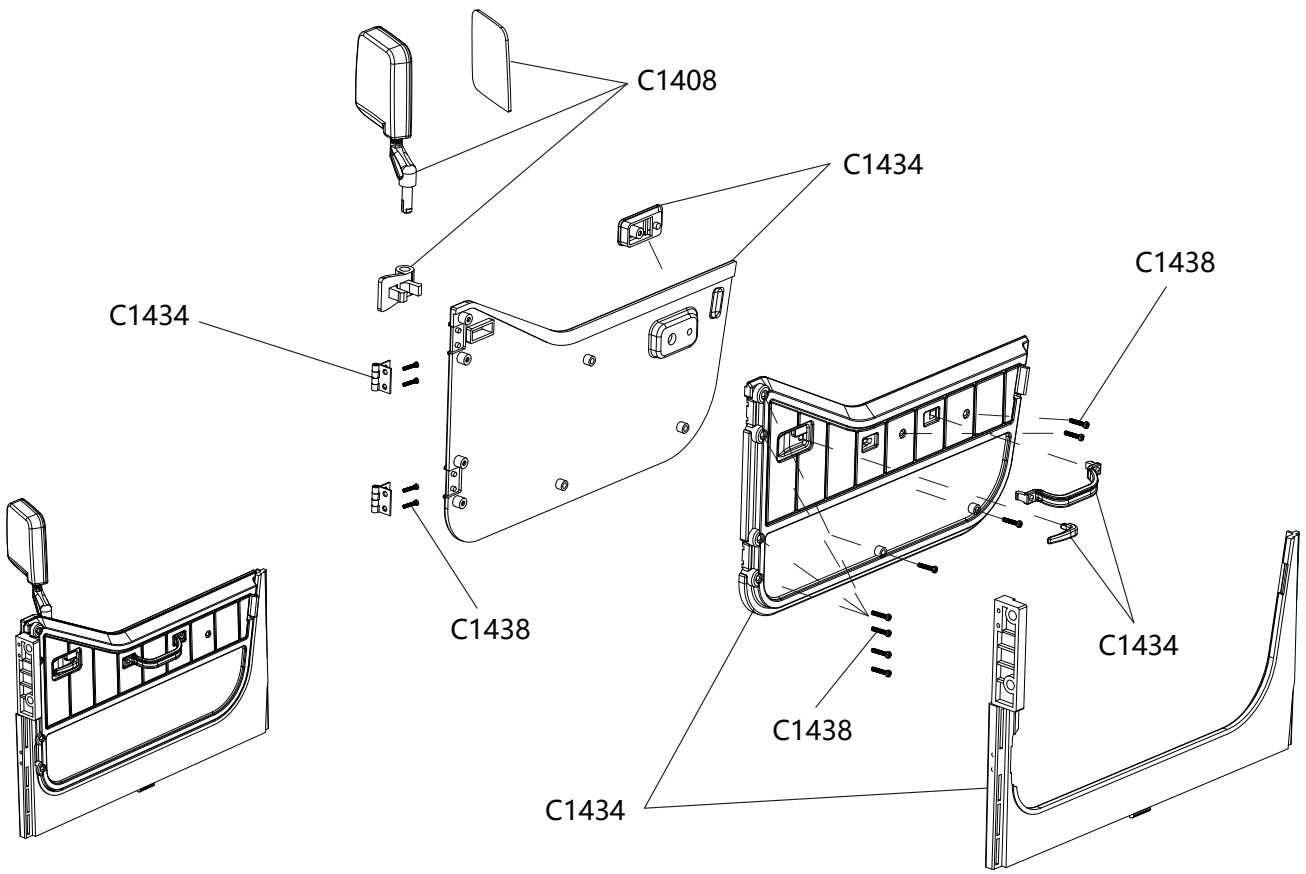
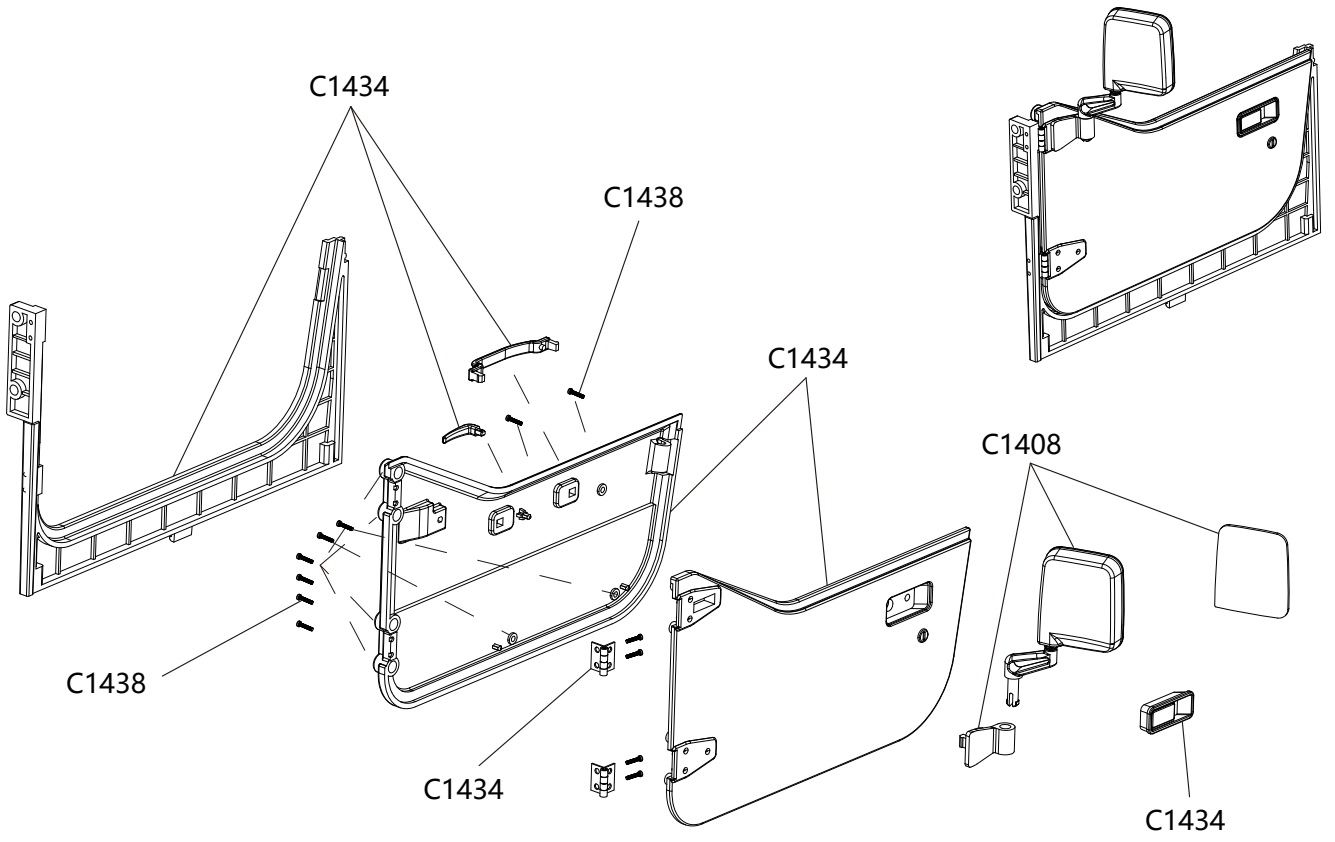

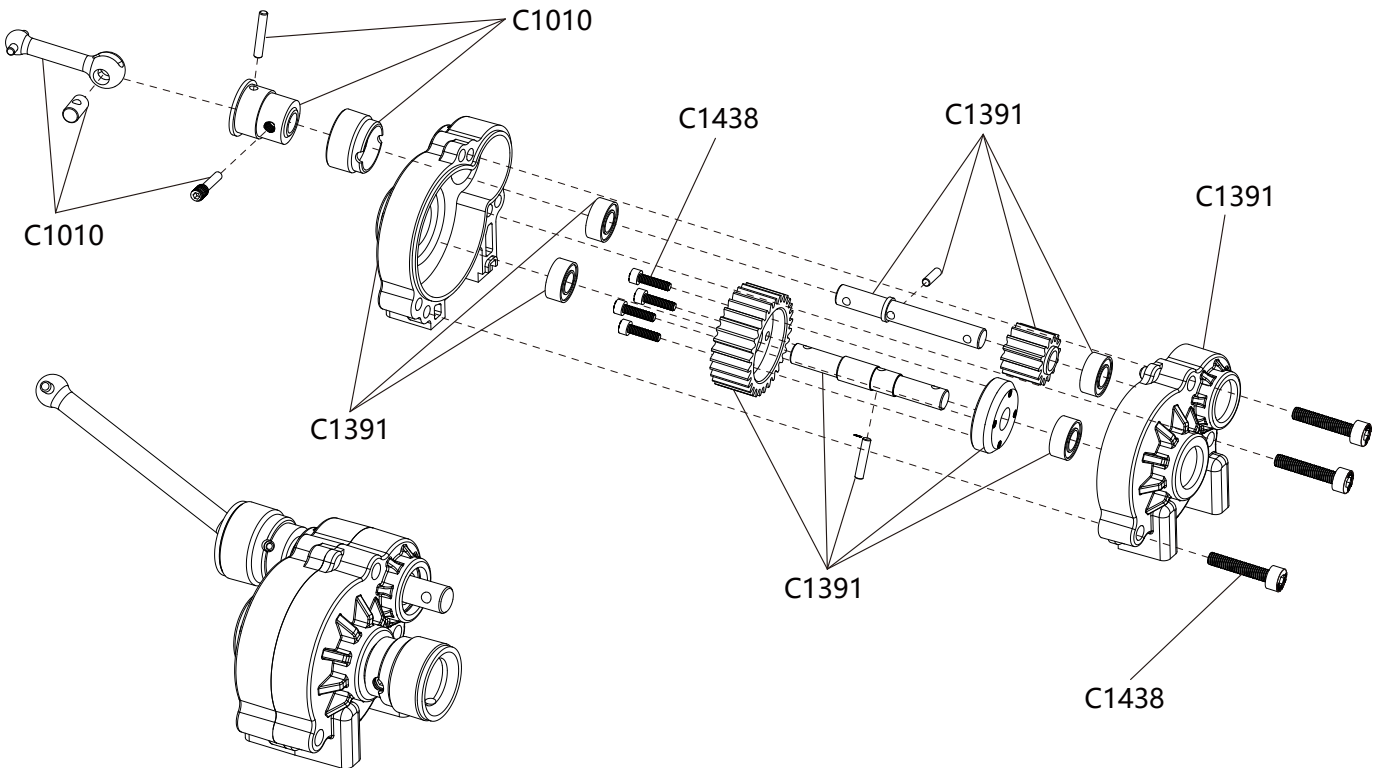
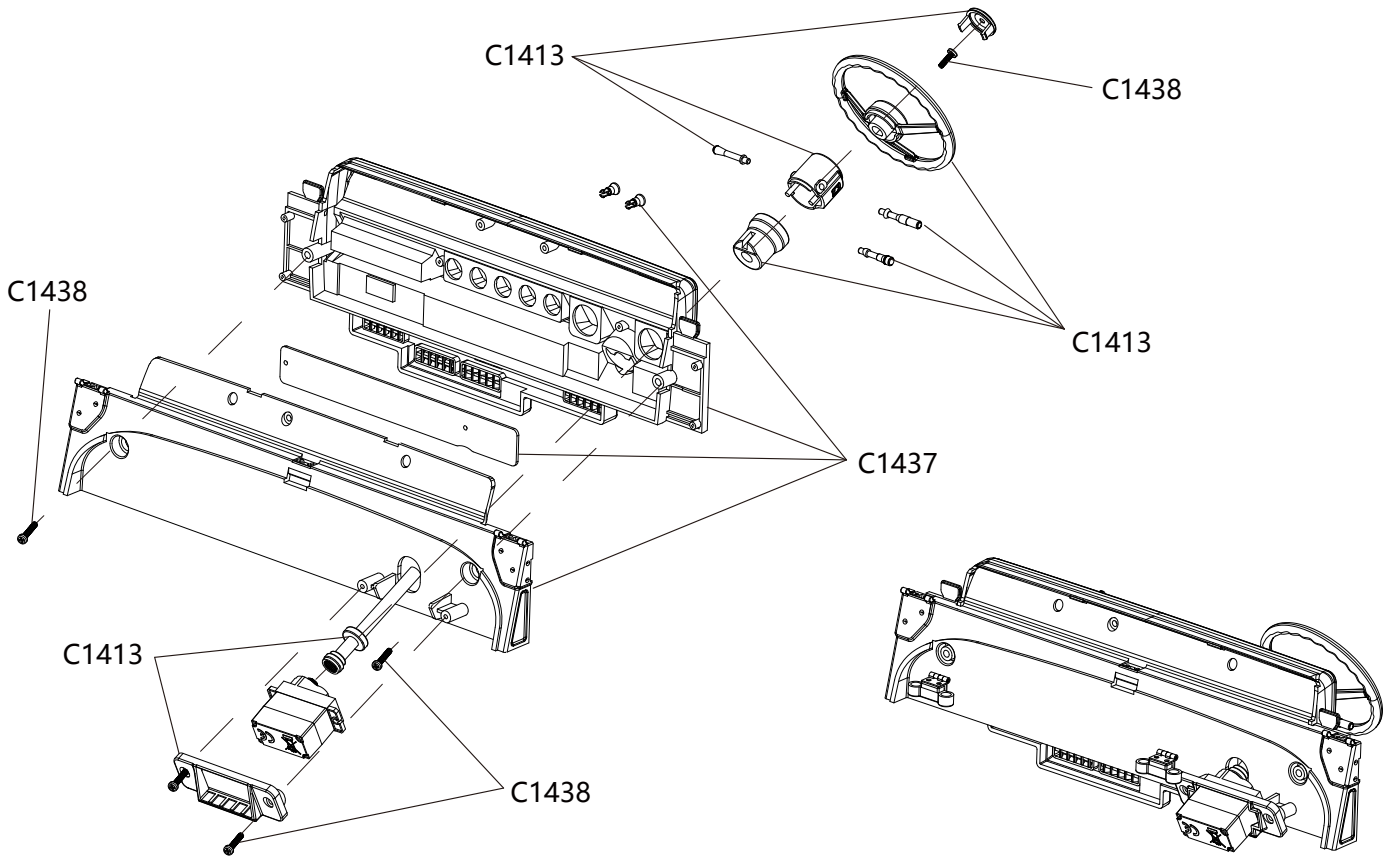

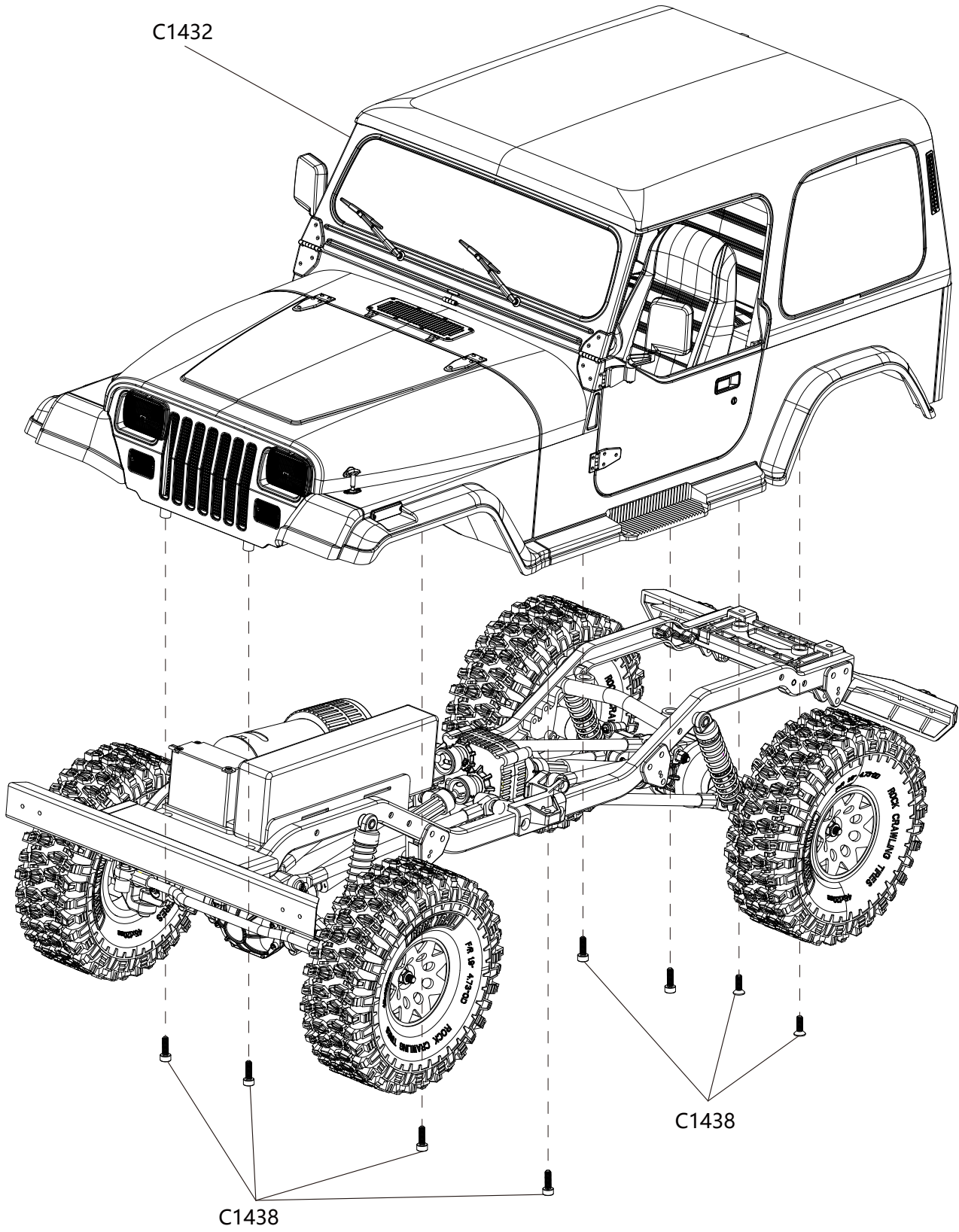

RO HOBBY

MADE IN CHINA
CE   FC